

DIGITAL STORAGE OSCILLOSCOPE

CS-8010

INSTRUCTION MANUAL

KENWOOD CORPORATION

KENWOOD

SAFETY

Symbol in This Manual



This symbol indicates where applicable cautionary or other information is to be found.

Power Source

This equipment operates from a power source that does not apply more than 250 V rms between the supply conductors or between either supply conductor and ground. A protective ground connection by way of the grounding conductor in the power cord is essential for safe operation.

Grounding the Product

This equipment is grounded through the grounding conductor of the power cord. To avoid electrical shock, plug the power cord into a properly wired receptacle before connecting to the equipment input or output terminals.

Use the Proper Power Cord

Use only the power cord and connector specified for your product.

Use the Proper Fuse

To avoid fire hazard, use a fuse of the correct type.

Do not Operate in Explosive Atmospheres

To avoid explosion, do not operate this product in an explosive atmosphere.



Do not Remove Cover or Panel

To avoid personal injury, do not remove the cover or panel. Refer servicing to qualified personnel.

Voltage Conversion

If the power source is not applied to your product, contact your dealer. To avoid electrical shock, do not perform the voltage conversion.

CONTENTS

SAFETY	2	1. DC VOLTAGE MEASUREMENTS	23
FEATURES	3	2. MEASUREMENTS OF THE VOLTAGE BETWEEN TWO POINTS ON A WAVEFORM	24
SPECIFICATIONS	4	3. ELIMINATION OF UNDESIRE SIGNAL COMPONENTS	25
 PRECAUTIONS	7	4. VOLTAGE RATIO MEASUREMENT USING CURSORS	25
CONTROLS AND INDICATORS	8	5. TIME MEASUREMENTS	26
FRONT PANEL	8	6. TIME DIFFERENCE MEASUREMENT	26
REAR PANEL	13	7. PULSE WIDTH MEASUREMENTS	27
DIRECTIONS FOR USE	14	8. PULSE RISE TIME AND FALL TIME MEASUREMENTS	28
OPERATION	15	9. PHASE DIFFERENCE MEASUREMENTS	29
[A] OPERATIONS AS A GENERAL-USE OSCILLOSCOPE	15	10. TIME RATIO MEASUREMENT USING CURSORS ..	30
(1) NORMAL SWEEP DISPLAY OPERATION	15	11. FREQUENCY MEASUREMENTS	31
(2) SWEEP MAGNIFICATION OPERATION	16	12. RELATIVE MEASUREMENTS	32
(3) X-Y OPERATION	16	13. APPLICATION OF X-Y OPERATION	33
(4) VIDEO SIGNAL OBSERVATION	17	APPLICATION EXAMPLES AS A DIGITAL STORAGE OSCILLOSCOPE	34
(5) SINGLE SWEEP OPERATION	17	 MAINTENANCE	36
[B] READOUT OPERATION	17	RESETTING THE READOUT CALENDER AND CLOCK DISPLAY	37
[C] OPERATION AS A DIGITAL STORAGE OSCILLOSCOPE	17	ACCESSORIES	38
APPLICATION	23		
PROBE COMPENSATION	23		
TRACE ROTATION COMPENSATION	23		

FEATURES

The model CS-8010 is a digital storage oscilloscope available for dual-channel simultaneous sampling at the maximum sampling speed of 100 ns/word. With a storage capacity of 8 bits \times 2048 words, the CS-8010 offers an easy waveform storage, having been subject to complicated operation heretofore. Used as a general-use oscilloscope, it features a wide frequency band from DC to 20 MHz. The alphanumeric CRT readouts function displays the calendar/clock, the vertical axis input sensitivity, and the sweep time. The cursor function displays the voltage difference and the time difference between two cursor lines on the CRT. With these functions, the CS-8010 simplifies data collection through photography.

1. Easy waveform observation of sudden (burst), single, and transient phenomena, etc. with the storage function.
2. Up to a X40 magnification with the trigger point as the center in the storage function. The PULL X10 MAG controller expands up to a maximum of X400 magnification.
3. Simultaneous display of the real-time waveform and the storage waveform. Which facilitates comparing waveforms by reference to the storage waveform.
4. Simplified recording of the storage waveform using a pen recorder.

5. The pre triggering function enables observing waveforms before triggering, having been impossible for a general-use oscilloscope currently in use.

6. The readout function displays each scale factor on the CRT, eliminating troublesome confirmation of the range for waveform observation.

When the provided probe PC-33 is used, the vertical sensitivity display on the CRT will be magnified by 10 times.

7. The cursor measurement mode displays, in letters, voltage difference, voltage ratio, time difference, time ratio, frequency, and phase difference corresponding to the cursor movement. This display eliminates calculation having been made by an operator, resulting in accurate waveform observation.
8. Vertical axis has high sensitivity and wide bandwidth and especially covers fully specified frequency response at 5 mV/div.
9. Trigger coupling (HFREJ) assures triggering of signals containing high-frequency noise.
10. The FRAME-LINE switch provides selection of sync pulse for sweep triggering from small amplitude to large amplitude without adjusting when viewing composite video waveforms.

SPECIFICATIONS

CRT		150 mm rectangular with internal graticule
Acceleration Voltage		12 kV
Display Area		8 × 10 div (1 div = 10 mm)
VERTICAL AXIS (CH1 and CH2)		
Sensitivity		1 mV/div to 5 V/div, ±3%
Attenuator		12 steps, 1 mV/div to 5 V/div in 1-2-5 sequence. Vernier control for fully adjustable sensitivity between steps.
Input Impedance		1 MΩ ±2% approx. 22 pF
Frequency Response	DC	Real time DC to 20 MHz, within -3 dB (5 mV/div to 5 V/div) DC to 5 MHz, within -3 dB (1 mV/div and 2 mV/div)
	AC	Real time 5 Hz to 20 MHz, within -3 dB (5 mV/div to 5 V/div) 5 Hz to 5 MHz, within -3 dB (1 mV/div and 2 mV/div)
Rise Time		17.5 ns or less (20 MHz) 70 ns or less (5 MHz)
Crosstalk		-40 dB minimum
Operating Modes	CH1	Single trace
	CH2	Single trace
	ALT	Two-waveform display, alternately
	CHOP	Two-waveform display, chopped
	ADD	CH1 + CH2 added display
Chop Frequency		Approx. 250 kHz
Channel Polarity		Normal or inverted, channel 2 only inverted
⚠ Maximum Input voltage		500 Vp-p or 250 V (DC + AC peak)
HORIZONTAL AXIS		
		Input thru CH2, ×10 MAG not included
Operating Modes		With TRIG MODE switch, X-Y operation is selectable (storage mode is read only) CH1 ; Y axis CH2 ; X axis
Sensitivity		Same as vertical axis (CH2)
Input Impedance		Same as vertical axis (CH2)
Frequency Response	DC	DC to 500 kHz, -3 dB
	AC	5 Hz to 500 kHz, -3 dB
X-Y Phase Difference		3° or less at 50 kHz
⚠ Maximum Input Voltage		Same as vertical axis (CH2)
SWEEP		
Type	NORM	Triggering sweep
	AUTO	Sweep free runs in absence of trigger
	SINGLE	Single sweep
Sweep Time		1 s/div to 0.5 μs/div, ±3%, in 20 ranges, in 1-2-5 sequence. Vernier control provides fully adjustable sweep time between steps.
Sweep Magnification		×10 (ten times) ±5%
Linearity		±3% all ranges.
TRIGGERING		
Internal Sync	CH1	Triggered by CH1 signal
	CH2	Triggered by CH2 signal
	LINE	Triggered by line frequency
External Sync		EXT; Triggered by signal applied to EXT TRIG INPUT jack
External Sync Input Impedance		Approx. 1 MΩ, approx. 32 pF

⚠ Max. External Trigger Voltage		50 V (DC + AC peak)
Coupling		AC, HFREJ, DC, TV FRAME, TV LINE
Sync sensitivity	At NORM position	
	AC	Sync frequency range: 10 Hz to 20 MHz INT: 1 div, EXT: 0.1 Vp-p
	DC	Sync frequency range: DC to 20 MHz INT: 1 div, EXT: 0.1 Vp-p
	HFREJ	The sync frequency range is more than 10 kHz, and the minimum amplitude (voltage) required for sync is increased.
	TV	FRAME, LINE INT: 1 div, EXT: 0.1 Vp-p
	AUTO: Rating shown above is provided at 50 Hz or over.	
CALIBRATION VOLTAGE		1 V ±3%, square wave, positive polarity. 1 kHz ±3%
INTENSITY MODULATION		
Sensitivity		+ 5 V, positive voltage decreases brightness.
Input Impedance		Approx. 10 kΩ
Usable Frequency Range		DC to 2 MHz
⚠ Maximum Input Voltage		50 V (DC + AC peak)
Digital Storage Mode (Common to CH 1 & 2)		
Vertical resolution		8 bits (25 dots/div.)
Frequency response	DC	Effective Storage Frequency Bandwidth DC to 400 kHz
	AC	Effective Storage Frequency Bandwidth 5 Hz to 400 kHz
Rise time		Useful rise time: 160 ns or less
Horizontal resolution		11 bits (200 dots/div.): 1 s/div. to 20 μs/div. (100 dots/div. to 5 dots/div.): 10 μs/div. to 0.5 μs/div.
Sampling time		5 ms/word to 100 ns/word (1 s/div. to 20 μs/div.) Fixed to 100 ns/word above 20 μs/div.
Pen out	Output voltage	0.5 V/div. ±10%
	Output impedance	Approx. 2 kΩ
	Readout speed	50 ms/word
Pre triggering		0 div., 2.5 div., 5 div., and 7.5 div.
Operating system	Real	Real-time waveform display
	Store	Write/read of storage waveform
	R & S	Simultaneous display of real-time waveform and storage waveform (readout only)
	Pen	Storage waveform display (readout only)
	Start	Outputs storage waveform at PEN OUT terminals.
READOUT		
Calendar		Year/Month/Day/O'clock/Minute Clock accuracy: ±2 min./month Battery life: About 20,000 hours (at room temperature)
Set value		CH1/CH2 scale factor (with probe detection); V-UNCAL, ADD, INVERT Sweep scale factor (magnification conversion); SWEEP VARIABLE-UNCAL, X-Y

Cursor mode	$\Delta V1$:	Voltage difference between Δ REF and Δ cursors on a CH1 scale factor basis
	$\Delta V2$:	Voltage difference between Δ REF and Δ cursors on a CH2 scale factor basis
	ΔT :	Time difference between Δ REF and Δ cursors on the basis of sweep scale factor
	$1/\Delta T$:	Frequency between Δ REF and Δ cursors on the basis of sweep scale factor
		Ratio: Voltage ratio and time ratio between Δ REF and Δ cursors, supposing 5 div. on the CRT as 100%
	Phase: Phase difference between Δ REF and Δ cursors, supposing 5 div. on the CRT as 360°	
NOTE: The X-Y mode allows $\Delta V1$ measurement only.		
Cursor measurement	Resolution	10 bits
	Measurement accuracy	$\pm 4 \%$
	Measurable range	ΔV , Ratio: ± 3.6 div or more from the CRT center ΔT , $1/\Delta T$, Ratio, Phase: ± 4.6 div or more from the CRT center
TRACE ROTATION (Electrical, adjustable from front panel)		
POWER REQUIREMENT		
Line Voltage	AC 100 V/120 V/220 V $\pm 10\%$ 216 V – 250 V	
Line Frequency	50/60 Hz	
Power Consumption	Approx. 58 W	
DIMENSIONS (W × H × D)	319 (359) × 132 (145) × 380 (442) mm () dimensions include protrusion from basic outline dimensions	
WEIGHT	Approx. 9.6 kg	
ENVIRONMENTAL		
Within Specifications	10°C to 35°C, 85% max. relative humidity	
Full Operation	0°C to 40°C, 85% max. relative humidity	
ACCESSORIES SUPPLIED		
Probe	PC-33 (READOUT compatible probe) × 2 Attenuation 1/10 Input impedance 10 M Ω , 22 pF $\pm 10\%$	
Power supply cable	1	
Replacement Fuse	1.2A × 2, 0.8A × 2	
Instruction Manual	1	

* Circuit and rating are subject to change without notice due to developments in technology.

PRECAUTIONS



Plug configuration	Power cord and plug type	Factory installed instrument fuse	Line cord plug fuse
	North American 120 volt/60 Hz Rated 15 amp (12 amp max; NEC)	1.2 A, 250 V Fast blow 6 × 30 mm	None
	Universal Europe 220 volt/50 Hz Rated 16 amp	0.8 A, 250 V T. lag 5 × 20 mm	None
	U.K. 240 volt/50 Hz Rated 13 amp	0.8 A, 250 V Fast blow 6 × 30 mm	0.8 A Type C
	Australian 240 volt/50 Hz Rated 10 amp	0.8 A, 250 V Fast blow 6 × 30 mm	None
	North American 240 volt/60 Hz Rated 15 amp (12 amp max; NEC)	0.8 A, 250 V Fast blow 6 × 30 mm	None
	Switzerland 240 volt/50 Hz Rated 10 amp	0.8 A, 250 V Fast blow 6 × 30 mm	None

Fig. 1 Power Input Voltage Configuration

1. Check the power supply voltage before use. A voltage selector/fuse holder is provided on the left side of the AC inlet socket, on the rear panel of the set. The line voltage setting is indicated by a triangle mark above the fuse holder. If the voltage is different from the power supply in your area, set it correctly to prevent danger and malfunctions. Be sure to check the voltage before connecting the power plug to an AC outlet.
 - When converting the voltage, refer to the Maintenance section.
2. The CS-8010 should be installed at a place meeting the following conditions:
 - 1 Direct sunlight
 - 2 High temperature and humidity.
 - 3 Frequent mechanical vibration.
 - 4 Strong magnetic rays or impulse voltage possibly generated from equipment located nearby.
3. Never apply more than the maximum rated voltage to the oscilloscope input jacks.
 - ▲ CH1, CH2 input jacks:
500 Vp-p or 250 V (DC + AC peak)
 - EXT TRIG, Z AXIS input jacks:
50 V (DC + AC peak)

Never apply external voltage to the oscilloscope output terminals.
4. Do not increase the intensity more than required.
5. Never allow a small spot of high brilliance to remain on the screen for extended periods of time.
6. Never cover the ventilating holes in the top of the scope, as this will increase the temperature inside the case thereby causing malfunction.
7. When removing the case, observe the maintenance instruction contained in this manual to prevent a safety hazard because this instrument contains high voltage circuits.
8. To protect against safety hazards always ground the instrument using the GND terminals on the panel.
9. When turning on and off the POWER switch repeatedly, keep an interval of about 5 seconds. Faster on and off operation may cause malfunction to the instrument.
10. Do not use the provided PC-33 Probe with other measuring equipment because it incorporates a terminal for READOUT detection which might damage the other equipment.
11. For proper use of the calendar and clock display, be sure to adjust the date and time correctly. (Refer to the "Maintenance and Adjustment" section.)
12. The calendar and clock display are backed up by an incorporated battery. If the battery is nearly exhausted, the date and time will be delayed. If this happens, the incorporated battery must be replaced with a new one. Please contact your dealer or Kenwood service agent for assistance.

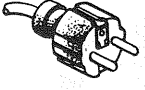
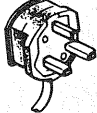
CONTROLS AND INDICATORS

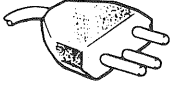
FRONT PANEL

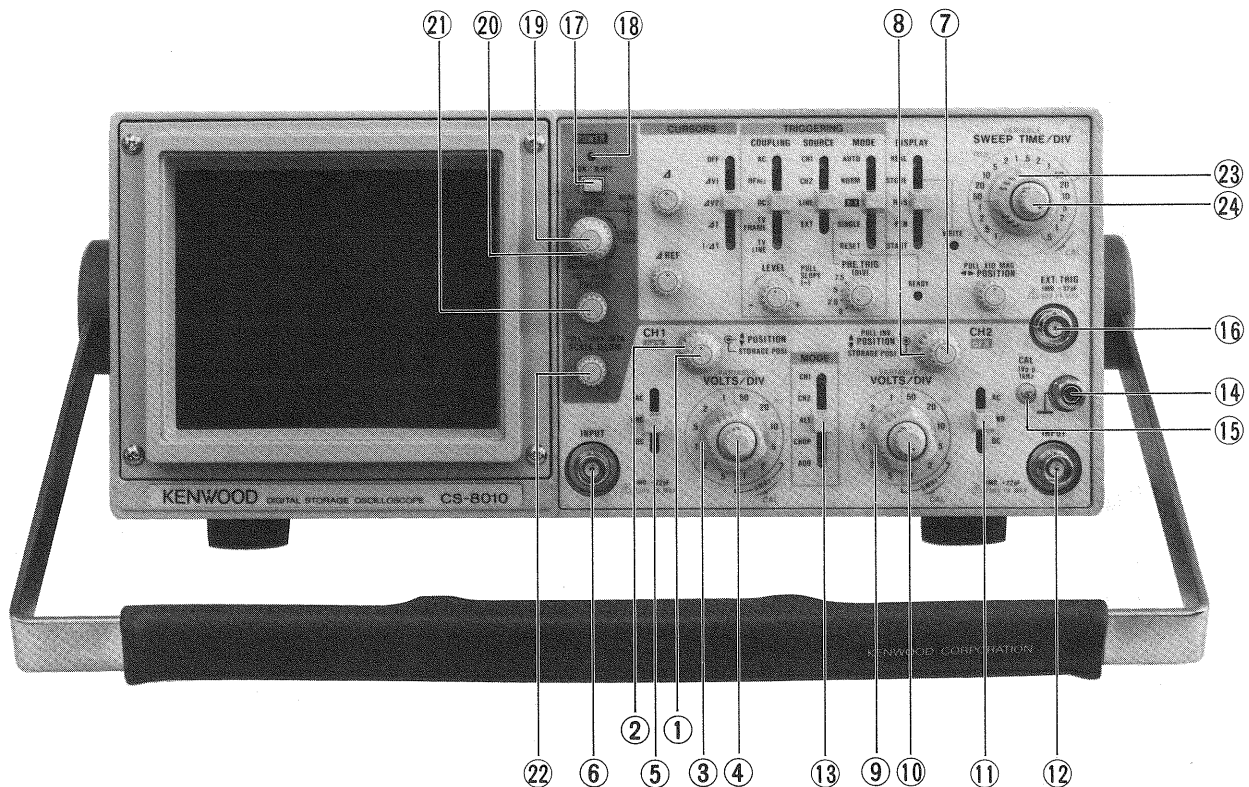

Fig. 2

① CH1 \updownarrow POSITION

Rotation adjusts vertical position of CH1 waveform on the screen. For X-Y operation, this control adjusts Y axis position.

In storage mode, this functions is the DC OFFSET adjustment of CH1, which superimposes a DC level over the input signal.

Clockwise rotation of the control adds +DC level to the GND level. Counterclockwise rotation adds -DC level to the GND level.

② CH1 STORAGE POSI

Controller for adjusting the vertical position of CH1 storage waveform. In the X-Y mode, it functions as a Y-axial position adjuster of the storage waveform.

③ CH1 VOLTS/DIV

Vertical attenuator for channel 1. Provides step adjustment of vertical sensitivity in 1-2-5 sequence. VARIABLE control is turned to the CAL position, the calibrated vertical sensitivity is obtained. For X-Y operation, this control serves as the attenuator for Y axis.

④ CH1 VARIABLE Control

Rotation provides fine control of channel 1 vertical sensitivity. In the fully clockwise (CAL) position, the vertical attenuator is calibrated. For X-Y operation, this control serves as the Y axis attenuation fine adjustment.

⑤ CH1 AC-GND-DC

This switch is the CH1 vertical axis coupling mode selector, for X-Y operation, the Y-axis coupling mode control.

AC: AC input coupling with blocking of any DC signal component.

GND: Vertical amplifier is disconnected from the input signal and connected to ground. This mode is useful in determining the zero reference.

DC: DC coupling, with both the DC and AC components of the input signal displayed on the CRT.

⑥ CH1 INPUT jack

Vertical input for channel 1 trace in normal sweep operation. Vertical input for X-Y operation.

⑦ \updownarrow CH2 POSITION/PULL INVert

\updownarrow CH2 POSITION:

Rotation adjusts vertical position of channel 2 trace.

INV: Push-pull switch selects channel 2 signal inverted (PULL INV) when pulled out.

(Hereafter PULL INV is described as CH2 INV.)

⑧ CH2 STORAGE POSI

Controller for adjusting the vertical position of CH2 storage waveform. In the X-Y mode, it functions as an X-axial position adjuster of the storage waveform.

⑨ **CH2 VOLTS/DIV**

Vertical attenuator for CH2. Provides the same function as VOLTS/DIV Control ③ for CH1. In X-Y operation, the control serves as the X-axis attenuator.

⑩ **CH2 VARIABLE Control**

Rotation provides fine control of channel 2 vertical sensitivity.

Provides the same function as VARIABLE Control ④ for CH1.

For X-Y operation, this control serves for X-axis attenuation fine adjustment.

⑪ **CH2 AC-GND-DC**

Three-position lever switch which operates as follows:

AC: Blocks dc component of channel 2 input signal.

GND: Opens signal path and grounds input to vertical amplifier. This provides a zero-signal base line, the position of which can be used as a reference when performing dc measurements.

DC: Direct input of ac and dc component of channel 2 input signal.

⑫ **CH2 INPUT Jack**

Vertical input for channel 2 trace in normal sweep operation. External horizontal input in X-Y operation.

⑬ **MODE**

Selects the basic operating modes of the oscilloscope.

CH1: Only the input signal to channel 1 is displayed as a single trace.

CH2: Only the input signal to channel 2 is displayed as a single trace.

ALT: Alternate sweep is selected regardless of sweep time.

CHOP: Chop sweep is selected regardless of sweep time at approximately 250 kHz.

ADD: The waveforms from channel 1 and channel 2 inputs are added and the sum is displayed as a single trace. When the CH2 INV ⑦ button is engaged, the waveform from channel 2 is subtracted from the channel 1 waveform and the difference is displayed as a single trace.

⑭ **⏏ GND terminal/binding post.**

Earth and chassis ground.

⑮ **CAL**

Provides 1 kHz, 1 V peak-to-peak square wave signal.

This is useful for probe compensation adjustment.

⑯ **EXT TRIG INPUT Jack**

Input terminal for external sync signal.

When SOURCE switch is selected in EXT position, the input signal at the EXT TRIG INPUT jack becomes the trigger.

⑰ **POWER**

Power switch. A press of this switch turns the power ON.

⑱ **POWER LED**

Lights when the POWER switch is pressed.

⑲ **INTEN (REAL)**

Controller for adjusting brightness of the real-time waveform bright line.

⑳ **INTEN (READOUT/STORE)**

Controller for adjusting brightness of the storage waveform bright line and the READOUT value.

* By turning the controller up to the very end both clockwise and counterclockwise, the storage bright line becomes brightest; by setting it to the center (3 o'clock position), it disappears. By turning the controller clockwise up to the very end, the READOUT value becomes brightest; turning counterclockwise turns readout function OFF and makes the value disappear.

㉑ **FOCUS/PULL ASTIG**

FOCUS: Focus adjustment

ASTIG: Used to bring the waveform into the best condition with the FOCUS adjustment by adjusting trace and spot aberration. Pull the knob to make a spot circular.

㉒ **SCALE ILLUM/PULL TRACE ROTA**

SCALE ILLUM: Brightness adjustment of the scale of the CRT. For photographing, rotate the knob to adjust brightness to prevent halation caused by too bright illumination.

TRACE ROTA: Tilt adjustment of the horizontal bright line in the case where geomagnetism influences the bright line to tilt.

㉓ **SWEEP TIME/DIV**

Range select dial of 20 ranges from 1 sec/div. to 0.5 μ s/div.

To calibrate the set value, rotate the SWEEP VARIABLE controller ㉔ clockwise up to the CAL position. In the storage mode, the range from 10 μ s/div. to 0.5 μ s/div. causes magnified sweep, resulting in lowering of horizontal resolution.

㉔ **SWEEP VARIABLE Control**

Fine sweep time adjustment. In the fully clockwise (CAL) position, the sweep time is calibrated.

In storage mode, however, it cannot be varied, as the CAL status is maintained.

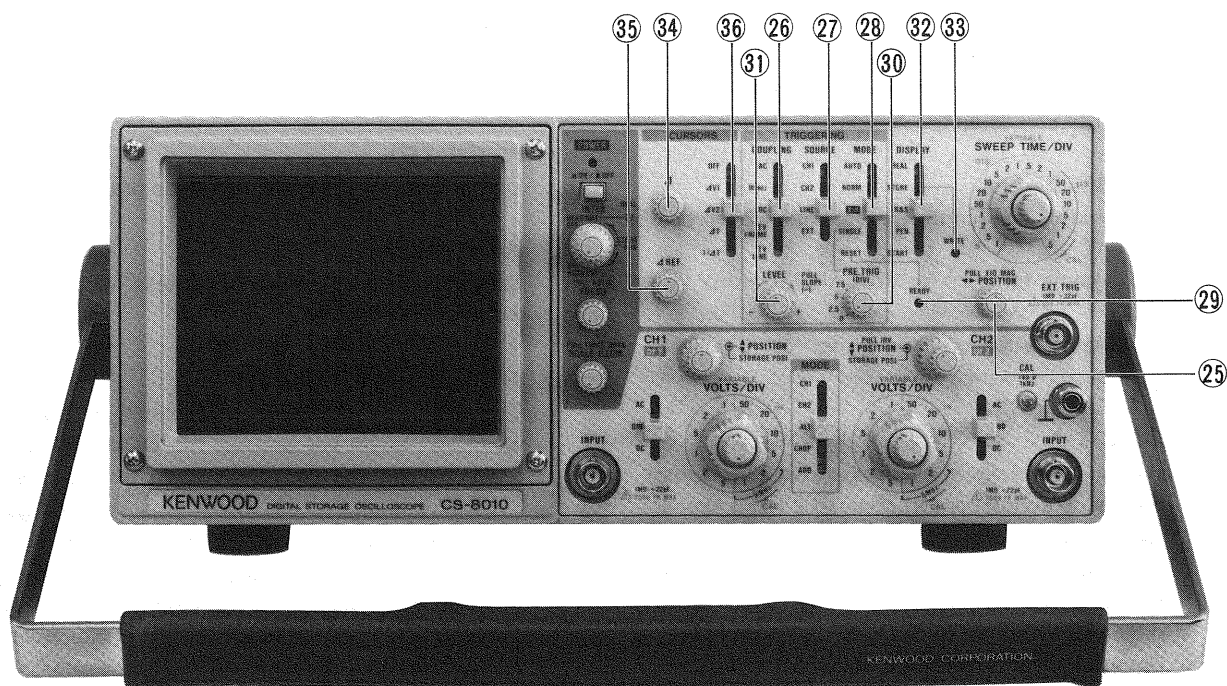

Fig. 3

②⑤ ◀▶ POSITION/PULL × 10 MAG

Horizontal position controller, which provides horizontal shift of waveform. By pulling the knob, the sweep time is quickened ten times.

In the X-Y operation mode. It functions as an X position controller. Also functions as an X position controller of the storage waveform.

NOTE: In X-Y operation, keep this knob pressed (normal sweep mode).

②⑥ COUPLING

Selects coupling for sync trigger signal.

AC: Trigger is AC coupled. Blocks DC component of input signal; most commonly used position.

HFrej: Sync signal is DC coupled through a low-pass filter to eliminate high frequency components for stable triggering of low frequency signals.

DC: The sync signal is DC coupled for sync which includes the effects of DC components.

TV FRAME: Vertical sync pulses of a composite video signal are selected for triggering.

TV LINE: Horizontal sync pulses of a composite video signal are selected for triggering.

②⑦ SOURCE

Sweep trigger source select switch.

CH1: Channel 1 signal is used as a trigger source.

CH2: Channel 2 signal is used as a trigger source.

LINE: Sweep is triggered by line voltage (50/60 Hz).

NOTE: When the COUPLING switch is set to other than AC position, the synchronization cannot be carried out. Be

sure to set the COUPLING switch to AC position.

EXT: Sweep is triggered by signal applied to EXT TRIG INPUT jack ①⑥.

②⑧ TRIG MODE

Selects triggering mode.

AUTO: Triggered sweep operation when trigger signal is present, automatically generates sweep (free runs) in absence of trigger signal.

NORM: Normal triggered sweep operation. No trace is presented when a proper trigger signal is not applied.

X-Y: X-Y operation. Channel 1 input signal produces vertical deflection (Y axis). Channel 2 input signal produces horizontal deflection (X axis).

This operates regardless vertical MODE selection.

NOTE: In storage mode, only the readout operation is possible. The write operation is disabled.

SINGLE: Single-sweep mode

Digital storage pre trigger mode in single sweep operation. The trigger point can be set from 0 to 7.5 div. with the PRE TRIG select switch ③①.

NOTE: Dual-trace single-sweep observation is not possible if the vertical operation MODE is set to ALT. Be sure to set the MODE to CHOP.

RESET: Reset mode of single-sweep operation. When reset, the switch returns to the SINGLE position, with the READY LED 29 lighting until completion of sweep. In storage mode, start the operation manually.

29 READY LED

When reset in single-wave operation, this lamp lights and remains lit until the sweep operation is completed. In storage mode, this lamp lights after a write operation is enabled, showing that the unit is in the trigger signal waiting status. In PRE TRIG mode, this lamp lights after the write inhibit period is finished, showing that the unit is in the trigger signal waiting status.

30 PRE TRIG

Mode for observing waveform prior to trigger signal. To observe it, set the select switch to a value from 2.5 to 7.5 div. If it is set to 2.5 div., waveform prior to trigger signal is displayed in the range of the left-hand 2.5 divisions, while waveform posterior to trigger signal is displayed in the range of the right-hand 7.5 divisions. When the switch is set to 0 div., waveform prior to trigger signal cannot be observed since the CS-8010 functions as a general-use oscilloscope with the trigger point at the left end on the CRT. For details on pre-triggering, refer to description items "SINGLE" and "RESET" of the TRIGGERING MODE switch 28.

NOTE: Do not switch the PRE TRIG switch between 0 dB and 2.5 to 7.5 div while the DISPLAY select switch 32 is set to a readout-only mode of R&S or PEN: otherwise the start point error would occur making normal waveform observation impossible.

31 LEVEL/PULL SLOPE (-)

LEVEL: Trigger level adjustment determines point on waveform where sweep starts. When COUPLING switch is selected in TV-FRAME or LINE, the trigger level adjustment has no effect.

PULL SLOPE (-) Switch:

Two-position push-pull switch. Pulled out position selects negative going (-) slope and pushed in position selects positive-going (+) slope as triggering point.

32 DISPLAY

REAL: Functions as a general-use oscilloscope. Data is not written in the memory.

STORE: Functions as a digital storage oscilloscope. Data is written and read out in/from the memory. Lighting of the WRITE LED indicates that data is being written in the memory. Do not operate the control knobs during a write operation, as normal waveform may not be output.

NOTE: CH1 and CH2 are written simultaneously even when the MODE select switch 13 is set to ALT.

R & S: Displays both real-time waveform and storage waveform. The storage waveform is for readout only, and is not written in the memory. Therefore, the vertical attenuator and SWEEP TIME controls, etc. do not function for storage waveforms. As they function only for real-time waveforms, be tions only for real-time waveforms, be

careful when using READOUT. (When the cursor storage waveform measurement is used other than when in write range, the correct display may not be obtained.)

PEN: Displays the storage waveform (readout only). The storage waveform (readout only) is displayed.

Therefore, if READOUT is used other than when in write range, the correct display may not be obtained.

START: Pen start setting for outputting storage waveform at the PEN OUT terminals on the rear panel. When waveform begins to be output, the pen speed is read out and the switch returns to the PEN position. During pen operation, bright line is displayed on the CRT, and the READOUT value disappears.

NOTE: When the MODE select switch 13 is set to ADD, the PEN OUT signal is output from CH1.

33 WRITE LED

Lights while the DISPLAY select switch 32 is set to the STORE position and data is being written in the memory. Either trigger signal or setting the MODE select switch 28 to SINGLE-RESET position to cause the pre trigger mode starts data writing.

When the DISPLAY select switch 32 is changed to another position, data writing into the memory is discontinued, and the stored waveform is nullified.

34 Δ

Controller for shifting the measuring cursor (rough dotted line) out of two cursor lines displayed on the CRT in the cursor measurement. By rotating the controller clockwise, the cursor line moves upward or rightward: by rotating counterclockwise, it moves downward or leftward.

35 Δ REF

Controller for shifting the reference cursor (small dotted line) out of two cursor lines displayed on the CRT in the cursor measurement. By rotating the controller clockwise, the cursor line moves upward or rightward: by rotating counterclockwise, it moves downward or leftward.

36 CURSORS

Cursor measurement mode select switch.

OFF: Cursor measurement is not performed. The cursor, and cursor measurement mode and cursor measurement value are not displayed on the CRT.

ΔV1: Two horizontal cursor lines are displayed on the CRT, and voltage difference and voltage ratio between them are displayed in the upper right on the CRT posterior to the cursor measurement mode display.

Setting the CH1 VARIABLE controller 4 to the CAL position causes voltage difference measurement, and a value calculated in accordance with setting of the CH1 VOLTS/DIV dial 3 is displayed posterior to ΔV1.

Setting the CH1 VARIABLE controller 4 to the UNCAL position causes voltage ratio measurement, and a value calculated assuming that 5 div. is 100% is displayed posterior to the RATIO.

When the Δ cursor is below the Δ REF cursor, a negative value is displayed.

NOTE: Setting of the MODE select switch 13 to the CH2 position causes Δ V2 mode cursor measurement.

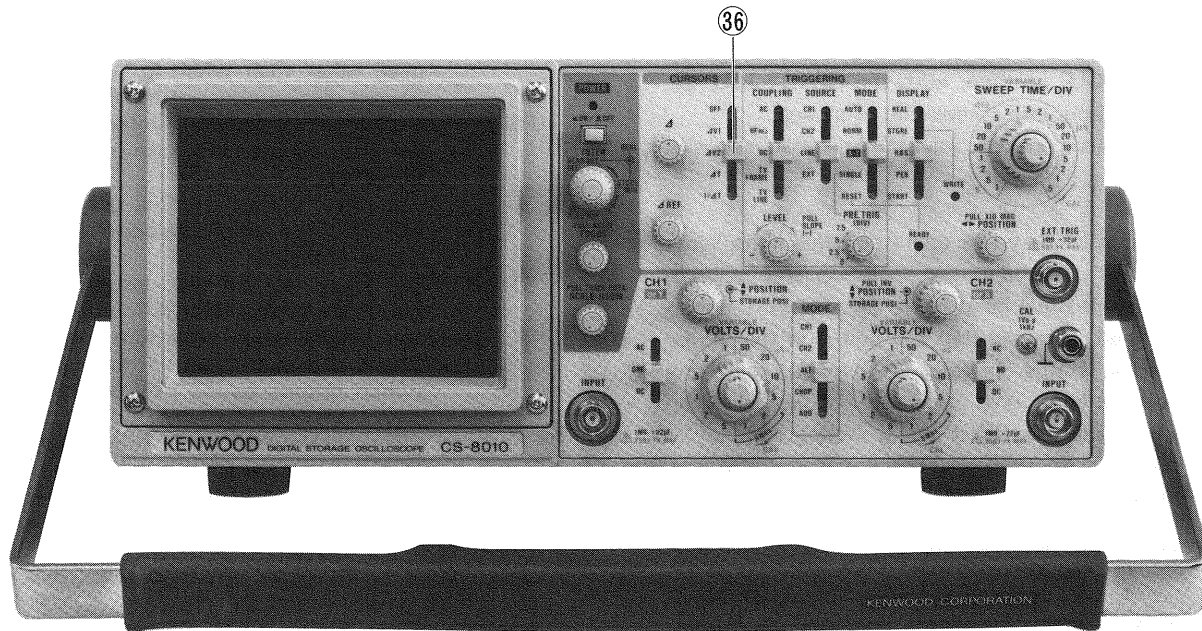

Fig. 4

$\Delta V2$: Two horizontal cursor lines are displayed on the CRT, and voltage difference and voltage ratio between them are displayed in the upper right on the CRT posterior to the cursor measurement mode display.

Setting the CH2 VARIABLE controller (10) to the CAL position causes voltage difference measurement, and a value calculated in accordance with setting of the CH2 VOLTS/DIV dial (9) is displayed posterior to $\Delta V2$.

Setting the CH2 VARIABLE controller (10) to the UNCAL position causes voltage ratio measurement, and a value calculated on the basis of 5 div. as 100% is displayed posterior to the RATIO.

When the Δ cursor is below the Δ REF cursor, a minus value is displayed.

NOTE: Setting of the MODE select switch (13) to the CH1 position causes $\Delta V1$ mode cursor measurement.

Setting of the MODE select switch (28) to the X-Y position disables $\Delta V2$ mode measurement.

ΔT : Two vertical cursor lines are displayed on the CRT, and time difference and time ratio between them are displayed in the upper right on the CRT posterior to the cursor measurement mode display.

Setting the SWEEP VARIABLE controller (24) to the CAL position causes time difference measurement, and a value calculated in accordance with setting of the SWEEP TIME/DIV dial (23) is displayed posterior to ΔT .

Setting the SWEEP VARIABLE controller (24) to the UNCAL position causes time ratio measurement, and a value calculated assuming that 5 div. is 100% is displayed posterior to the RATIO.

When the Δ cursor is on the left of the Δ REF cursor, a minus value is displayed.

NOTE: Setting of the MODE select switch (28) to the X-Y position disables ΔT mode measurement.

$1/\Delta T$: Two vertical cursor lines are displayed on the CRT, and frequency and phase difference between them are displayed in the upper right on the CRT posterior to the cursor measurement mode display.

Setting the SWEEP VARIABLE controller (24) to the CAL position causes frequency measurement, and a value calculated in accordance with setting of the SWEEP TIME/DIV dial (23) is displayed posterior to $1/\Delta T$.

Setting the SWEEP VARIABLE controller (24) to the UNCAL position causes phase difference measurement, and a value calculated assuming that 5 div. is 360° is displayed posterior to the PHASE.

When the Δ cursor is on the left of the Δ REF cursor, a minus value is displayed. However, frequency is displayed in an absolute value.

NOTE: Setting of the MODE select switch (28) to the X-Y position disables $1/\Delta T$ mode measurement.

CONTROLS AND INDICATORS

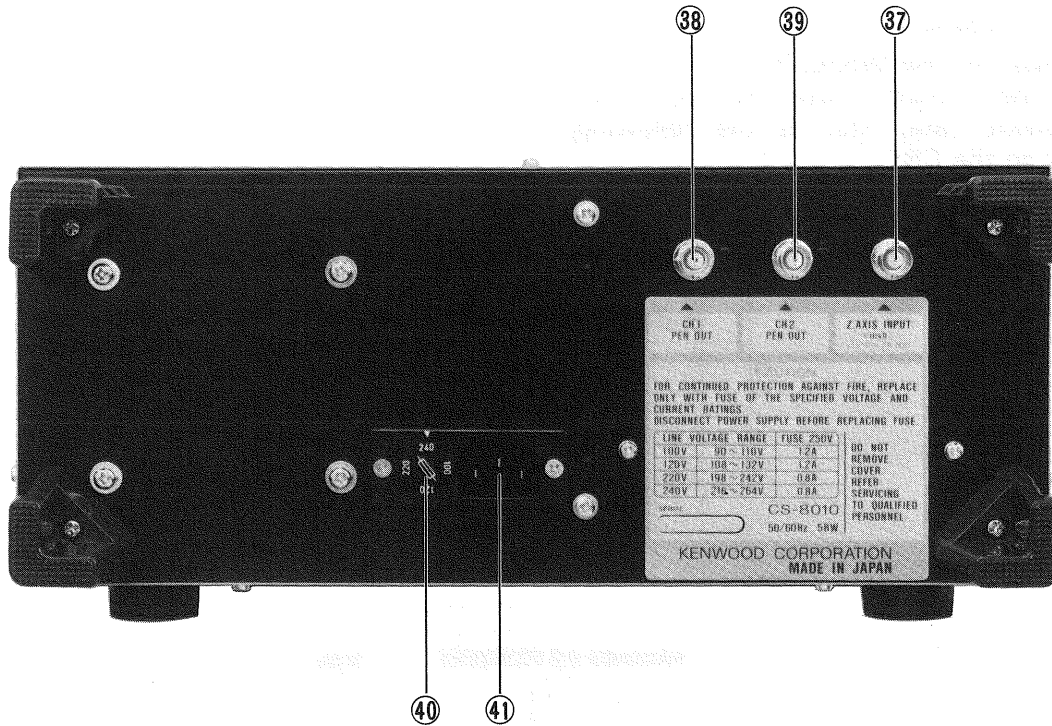

Fig. 5

REAR PANEL

37 Z AXIS INPUT

External intensity modulation input; TTL compatible. Positive voltage increases brightness, negative voltage decreases brightness.

38 CH1 PEN OUT

Storage waveform output terminal for channel-1 pen recorder. Setting the DISPLAY select switch 32 on the front panel to the START position starts output. When the MODE select switch 13 is set to the ADD position, synthetic storage waveform of channels 1 and 2 is output.

NOTE: When the MODE select switch 13 is set to the CH2 position, channel-1 waveform is not output.

39 CH2 PEN OUT

Storage waveform output terminal for channel-2 pen recorder. Setting the DISPLAY select switch 32 on the front panel to the START position starts output.

NOTE: When the MODE select switch 13 is set to the CH1 or ADD position, channel-2 waveform is not output.

40 Fuse Holder, Line Voltage Selector

Contains the line fuse. Verify that the proper fuse is installed when replacing the line fuse.

100 V, 120 V1.2 A
220 V, 240 V0.8 A

After pulling the power cord plug from the power outlet, adjust this selector to your line voltage.

41 Power Input Connector

Input terminals of power supply. Connect the AC cord provided.

DIRECTIONS FOR USE

READOUT DISPLAY

(1) POSITIONS OF THE DISPLAY

Displays the calendar, scale factors, cursor measurement data, etc. at the following positions on the CRT.

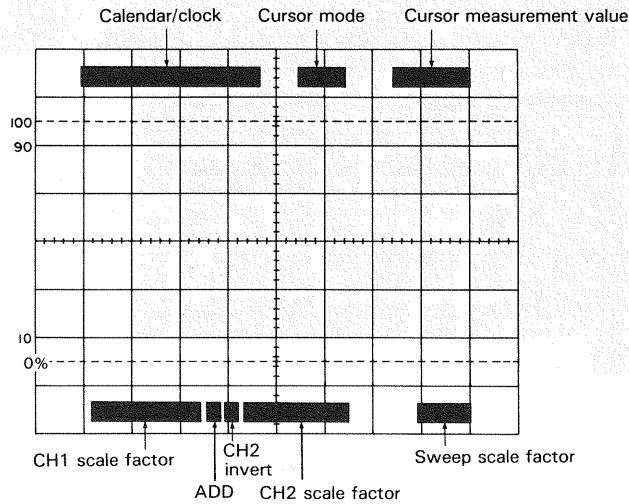

Fig. 6

(2) DISPLAY CONTENTS

1 Calendar/Clock

Displays a calendar and clock in the following order:

Month-Day-Year-O'clock-Minute

Month: JAN, FEB, MAR, APR, MAY, JUN, JUL,
AUG, SEP, OCT, NOV, DEC

Day: 01 to 31

Year: 00 to 99

O'clock: 00 to 23

Minute: 00 to 59

These setting can be changed with the switch located on the bottom. (For resetting, refer to the Maintenance section.)

2 Cursor Mode

The current setting cursor mode, which depends on the combination of the operation controls, is displayed.

$\Delta V1$, $\Delta V2$, ΔT , $1/\Delta T$, RATIO, PHASE

3 Cursor Measuring Data

The result measured by the two cursors is displayed. In the $1/\Delta T$ mode, when the two cursors approach each other and the measurement nears its limit, a "?" will be displayed in front of the measured data. This shows that the measured data is not available.

4 CH1 Scale Factor

Displays the CH1 vertical axis sensitivity to one division. When not in CAL mode, a ">" is displayed after CH1.

NOTE: This is not displayed when the MODE control ⑬ is set to CH2.

5 CH2 Scale Factor

Displays the CH2 vertical axis sensitivity to one division. When not in CAL mode, a ">" is displayed after CH2.

NOTE: This is not displayed when the MODE control ⑬ is set to CH1.

6 ADD

"+" is displayed when the MODE control ⑬ is set to ADD.

7 CH2 INVERT

The inverted polarity of CH2 "I" is displayed by controlling the POSITION/PULL INV ⑦.

8 Sweep Scale Factor

Displays the sweep range set by the SWEEP TIME/DIV. When the SWEEP VARIABLE is not in CAL mode, a ">" is displayed. When TRIGGERING MODE is set to X-Y, this display is changed to "X-Y".

OPERATION

INITIAL STARTING PROCEDURE

Prior to turning the power ON, set the switches as in the drawing below in advance. For details of switch setting,

refer to the item "Front Panel". In the case of using a probe, refer to the Operation Manual attached to the probe as well as the application example "Probe Compensation".

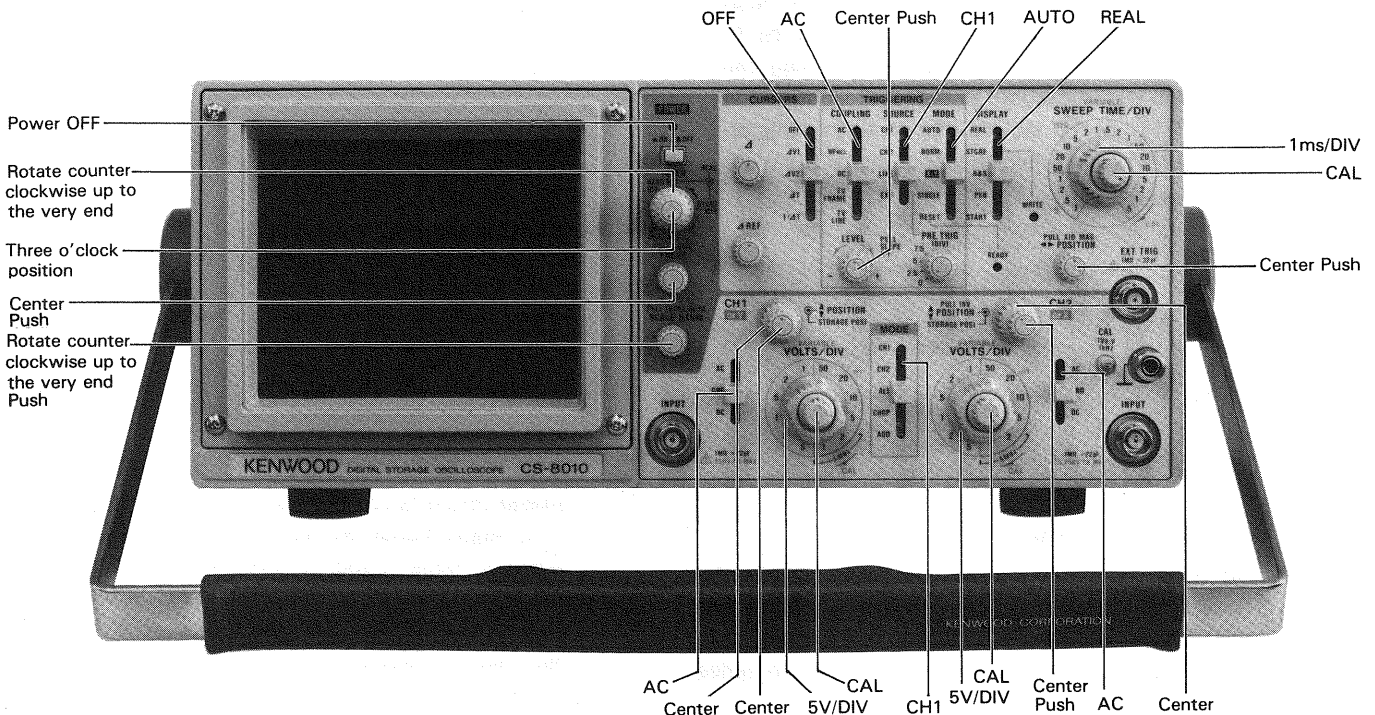

Fig. 7

[A] OPERATION AS A GENERAL-USE OSCILLOSCOPE

(1) Normal sweep display operation

1. Press the POWER switch (17) to supply power, and the POWER LED (18) lights.
2. A bright line appears in the CRT center. If it is not in the center, adjust its position to the center with the POSITION controller (1). Then, adjust the brightness with the INTENSITY controller (19), and the focus, with the FOCUS controller (21) as required for easy observation.
3. Supply input signal into the CH1 INPUT jack (6). Rotate the VOLTS/DIV dial (3) to adjust waveform to appropriate dimensions.

Set the MODE select switch (13) to CH2, and the TRIGGERING SOURCE select switch (27) to CH2. Then, supply input signal into the CH2 INPUT connector (12). Its waveform is displayed on the CRT in the same procedures with channel 1.

When the MODE select switch is set to ADD, the composite waveforms of CH1 and CH2 (the algebraic sum of CH1 + CH2) is displayed on the CRT. In this status, if CH2 INV is engaged by pulling out the CH2 (7) POSITION, the algebraic difference between CH1 and CH2 (CH1 - CH2) will be displayed.

The sensitivity of the ADDED waveform becomes the same as the value indicated by VOLTS/DIV provided that the same VOLTS/DIV value has been set for the waveforms of the two channels.

When the MODE select switch (13) is set to ALT, the channel-1 and channel-2 waveforms are displayed alternately in every sweep. In this case, the SOURCE select switch (27) should be set to the channel to be synchronized.

4. The display on the screen will probably be unsynchronized. Refer to TRIGGERING procedure below for adjusting synchronization and sweep speed to obtain a stable display showing the desired number of waveform.

TRIGGERING

The input signal must be properly triggered for stable waveform observation. TRIGGERING is possible the input signal INTERNALLY to create a trigger or with an EXTERNALLY provided signal of timing relationship to the observed signal, applying such a signal to the EXT. TRIG INPUT jack (16).

- (1) The selection of a signal that serves as the trigger signal is made using the SOURCE switch (27).

★ Internal Sync

When the SOURCE selection is in INT (CH1, CH2, LINE), the input signal is connected to the internal trigger circuit. In this position, a part of the input signal fed to the INPUT (6) or (12) jack is applied from the vertical amplifier to the trigger circuit to cause the trigger signal triggered with the input signal to drive the sweep.

Setting the SOURCE select switch (27) to LINE causes synchronization with commercial power frequency.

★ External Sync

When the SOURCE selection is in EXT, the input signal at the EXT TRIG INPUT (16) jack becomes the trigger. This signal must have a time or frequency relationship to the signal being observed to synchronize the display. External sync is preferred for waveform observation in many applications. For ex-

ample, Fig. 8 shows that the sweep circuit is driven by the gate signal when the gate signal in the burst signal is applied to the EXT. TRIG INPUT jack. Shows the input/output signals, where the burst signal generated from the signal is applied to the instrument under test. Thus, accurate triggering can be achieved without regard to the input signal fed to the INPUT ⑥ or ⑫ jack so that no further triggering is required even when the input signal is varied.

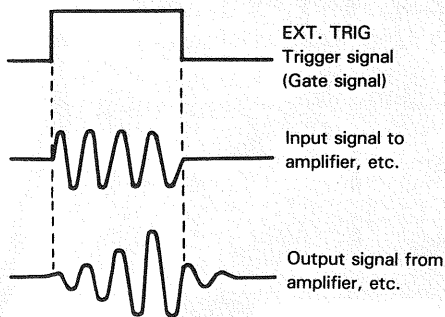

Fig. 8

NOTE: Since the EXT input is DC-coupled, if a DC voltage of more than 1.5 V is superimposed, sync will not be engaged. In this case, connect a capacitor of about 0.047 μ F in series and use AC coupling.

- (2) After the SOURCE has been set, the trigger point can be set by rotating LEVEL/SLOPE control
- (3) Setting of coupling switch

AC:

The trigger signal is capacitively coupled, so its DC component is cut, giving a stable trigger which is not affected by the DC component. With this advantage, this position of the coupling switch is conveniently selected for ordinary applications. However, if the trigger signal is lower than 10 Hz, the trigger signal level becomes attenuated, resulting in difficulty in triggering.

HF REJ:

The trigger signal is supplied through a low-pass filter to eliminate the high-frequency component (higher than 10 kHz), giving a stable triggering with low-frequency component. When high-frequency noise is superimposed over the trigger signal as shown in Fig. 9, the high-frequency noise is cut to provide a stable trigger.

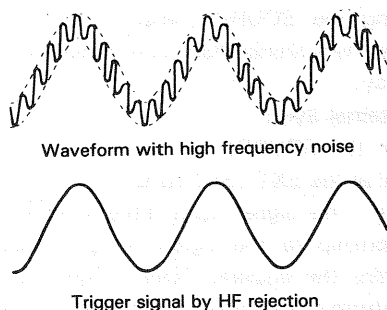

Fig. 9

★ Triggering Level

Trigger point on waveform is adjusted by the LEVEL/PULL SLOPE ③ control. Shows the relationship between the SLOPE and LEVEL of the trigger point. Triggering level can be adjusted as necessary.

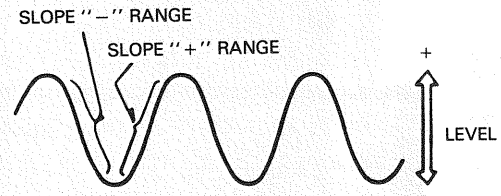

Fig. 10

★ Auto Trigger

When the TRIG MODE ⑲ selection is in AUTO, the sweep circuit becomes free-running as long as there is no trigger signal, permitting a check of GND level. When a trigger signal is present, the trigger point can be determined by the LEVEL control for observation as in the normal trigger signal. When the trigger level exceeds the limit, the trigger circuit becomes free-running where the waveform starts running.

NOTE: If, with the TRIG MODE switch set to NORM, no trigger signal is input or the trigger signal exceeds the triggering range, sweeping is stopped and trace will not be displayed.

5. Adjust the SWEEP TIME/DIV control ⑳ to obtain an appropriate display. Now a normal sweep display is obtained.

(2) Sweep magnification operation

Since merely shortening the sweep time to magnify a portion of an observed waveform can result in the desired portion disappearing off the screen, such magnified display should be performed if the sweep magnification feature is used (refer to "Sweep Magnification" or page 4.).

Using the ◀▶ POSITION control, adjust the desired portion of waveform to the CRT. Pull out the PULL \times 10 MAG control to magnify the display 10 times. For this type of display the sweep time is the SWEEP TIME/DIV setting divided by 10.

(3) X-Y operation

X-Y operation permits the oscilloscope to perform many measurements not possible with conventional sweep operation.

Set the TRIGGER MODE switch ⑲ to the X-Y position. In this mode, channel 1 becomes the Y axis input and channel 2 becomes the X axis input.

The X and Y positions are now adjusted using the ◀▶ POSITION ⑳ and CH1 ⬆ POSITION controls respectively. X and Y sensitivity are set by using the channel 2 and channel 1 VARIABLE VOLTS/DIV controls respectively.

(4) Video signal observation

Setting the COUPLING (26) switch, to the TV FRAME or TV LINE position permits selection of vertical or horizontal sync pulses for sweep triggering when viewing composite video waveforms.

This makes stable triggering in video signal observations possible regardless of the TRIG LEVEL control (31).

At most points of measurement, a composite video signal is of the polarity, that is, the sync pulses are negative and the video is positive. In this case, use "--" SLOPE.

If the waveform is taken at a circuit point where the video waveform is inverted, the sync pulses are positive and the video is negative. In this case, use "+ " SLOPE.

(5) Single sweep

Single sweep is used typically to sweep a nonperiodic waveform once only.

1. Set the TRIG MODE switch (28) to AUTO or NORM. For use as trigger input, connect a signal of practically the same amplitude and frequency as the signal to be displayed. Then set a trigger level.
2. Set the TRIG MODE switch (28) to REST. The LED labeled "READY" will go on, indicating the trigger wait state. The LED will go off upon completion of A sweep.
3. Being sure that the "READY" LED is lit, connect the signal to be observed, and set the TRIG MODE control (28) to REST so that the unit is waiting for trigger. Once the signal is triggered, it will be swept once and the "READY" LED will go off.

NOTE: Dual trace waveform cannot be observed if the vertical MODE is set to ALT. Use the CHOP mode instead.

[B] READOUT OPERATION

1 CRT surface readout

By rotating the INTEN (READOUT/STORE) controller (20) clockwise up to the very end, characters are displayed on the CRT. Adjust the brightness as necessity requires. The CH1 and CH2 scale factors are displayed in the lower part of the CRT in accordance with setting of the MODE select switch (13). The sweep scale factor is displayed in the lower right part. By pulling the ◀▶ POSITION/PULL × 10 MAG switch (25), a tenth scale factor of the SWEEP TIME/DIV dial (23) is displayed. The calendar is displayed in the upper left.

NOTE: If the DATA-ON/OFF switch on the bottom is set to the OFF position, the calendar and clock are not displayed. To set the calendar and clock, refer to "Maintenance and Adjustment".

When the readout values are displayed, brilliance modulation may influence the real-time waveform in some cases. In such a case, rotate the INTEN (READOUT/STORE) control (20) fully counterclockwise. The readout function will be turned OFF, and the brilliance modulation on the real-time waveform will disappear.

2 Cursor measurement

$\Delta V1$: Set the MODE select switch (13) to ALT and the CURSORS select switch (36) to $\Delta V1$, and two horizontal cursor lines are displayed on the CRT and voltage difference between cursor lines calculated in accordance with setting of the CH1 VOLTS/DIV dial (3) is displayed in the upper right on the CRT. By setting the CH1 VARIABLE controller (4) to the UNCAL position, voltage ratio is displayed.

Move the cursors to the positions to be measured with the ΔREF controller (35) and Δ controller (34).

$\Delta V2$: Set the CURSORS select switch (36) to $\Delta V2$, voltage difference in accordance with the CH2 range setting is displayed in the upper right on the CRT similarly with the above $\Delta V1$.

ΔT : Set the CURSORS select switch (36) to ΔT , and two vertical cursor lines are displayed on the CRT and time difference between the cursor lines calculated based on the sweep scale factor displayed in the lower right is displayed in the upper right. By setting the SWEEP VARIABLE controller (24) to the UNCAL position, time ratio is displayed.

$1/\Delta T$: Set the CURSORS select switch (36) to $1/\Delta T$, and two vertical cursor lines are displayed on the CRT and frequency between the cursor lines calculated based on the sweep scale factor displayed in the lower right is displayed in the upper right. By setting the SWEEP VARIABLE controller (24) to the UNCAL position, phase difference is displayed.

[C] OPERATION AS A DIGITAL OSCILLOSCOPE

(1) In normal oscilloscope mode (DISPLAY MODE-REAL), adjust the \blacktriangle (up/down) position so that the GND luminance line is at the center of the CRT.

In this condition, the storage range is 4 div. from the center of the scale on the CRT for both the upper and lower section. If a voltage exceeding ± 4 div. is input, the storage waveform will be clamped and normal waveform analysis will not be obtained.

If this is the case, set the vertical input coupler to AC or DC, and check that the waveform to be stored is present on the CRT.

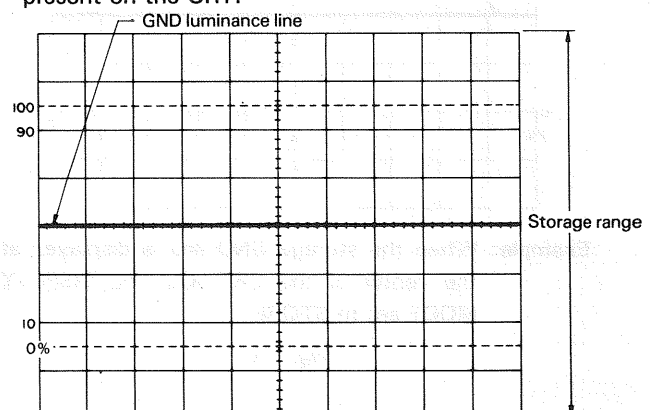

Example when the GND luminance line is set at the center of the CRT in DISPLAY MODE-REAL

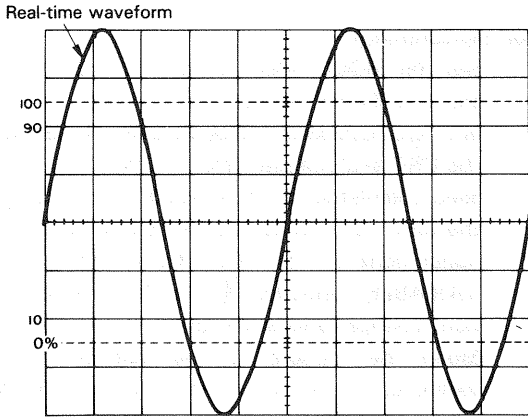

Fig. 12

Example: When checking that the waveform is present on the CRT after setting the AC-GND-DC switch to AC mode in DISPLAY MODE-REAL

- 2) Set the DISPLAY (32) to STORE, and turn the STORE INTEN (20) clockwise (to display READOUT and STORAGE data simultaneously) or counterclockwise (to display STORAGE data only). Adjust the luminance level, if required.

Set the AC-GND-DC switch to GND mode, and adjust the STORAGE POSI so that the storage GND luminance line is displayed at the center of the CRT. With this operation, the positions of the real-time waveform and the storage waveform are set correctly. (The real-time waveform and the storage waveform are superimposed completely when the DISPLAY MODE is set to R & S.)

When the AC-GND-DC switch is set to AC or DC, the WRITE LED (33) lights, to show that writing into memory is being performed. When writing is completed, the storage waveform will be displayed. In this mode, writing into memory or reading out from memory is performed at every trigger signal.

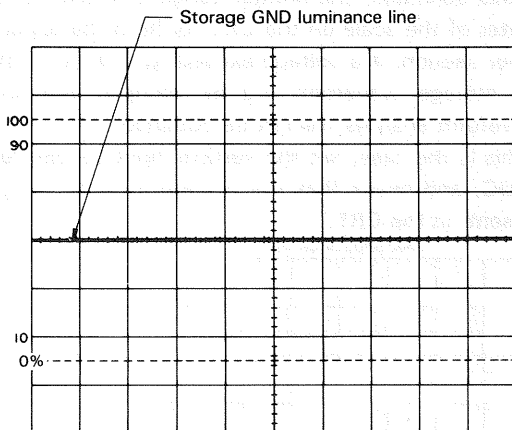

Example: When the storage GND line is displayed at the center of the CRT with the DISPLAY MODE set to STORE

Fig. 13

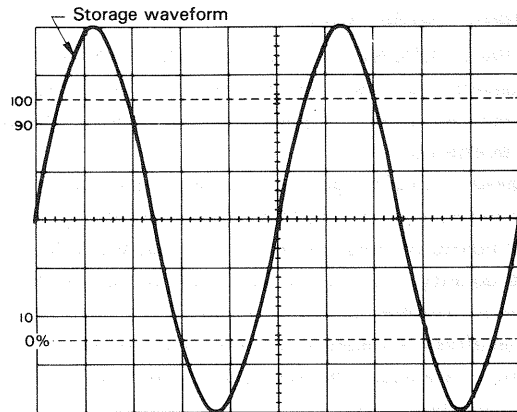

Fig. 14

Example: When storing a waveform after the AC-GND-DC switch is set to AC with the DISPLAY MODE set to STORE

- 3) When the DISPLAY (32) is set to R & S, both the real-time waveform and the storage waveform will be displayed. The storage waveform can be used for read out only. In this mode, comparison between a real-time waveform and a storage waveform is made possible. When the real-time waveform is made possible. When the real-time waveform and the storage waveform are superimposed, and thus hard to decipher, adjust the STORAGE POSI to shift the storage waveform to a position where it can be observed easily. In this case, if the real-time waveform is shifted with the POSITION, it will be necessary to check the GND level again, because it will be shifted when the waveform is stored by setting the DISPLAY MODE to STORE.

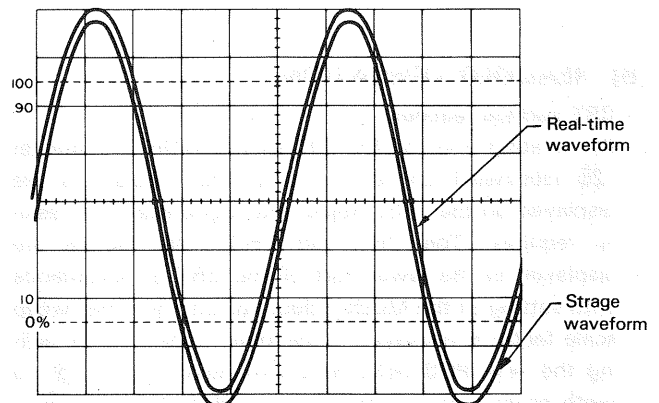

Fig. 15

Example: When the real-time waveform and the storage waveform are displayed simultaneously with the DISPLAY MODE set to R & S

- 4) When the DISPLAY (32) is set to PEN, only the storage waveform is displayed. The storage waveform can be used to read out only, and writing becomes impossible. Observe the waveforms in this mode. After matching the real-time GND level with the storage GND level, if the STORAGE POSI is turned, the GND level of the storage waveform will be varied. Be careful of this point when measuring the voltage.

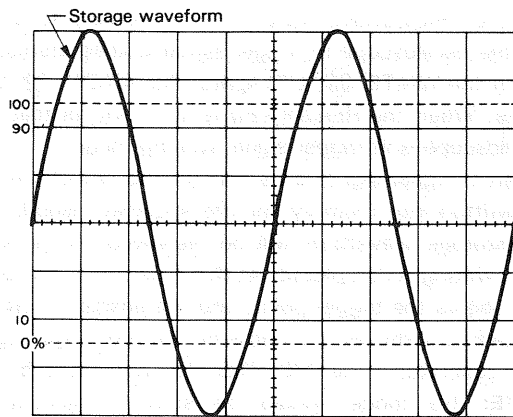

Fig. 16

Example: When freezing the storage waveform using the write pen with the DISPLAY MODE set to STORE

NOTE: Examples then the storage waveform is clamped by inputting an incorrect voltage are as follows:

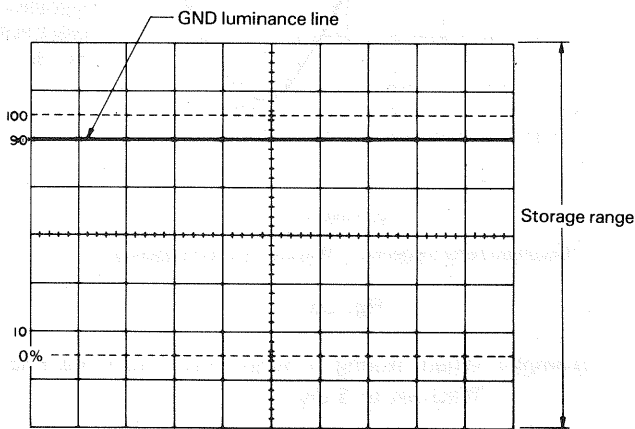

Fig. 17

When the GND luminance line is set at the 2 div. position, with the DISPLAY MODE set to REAL

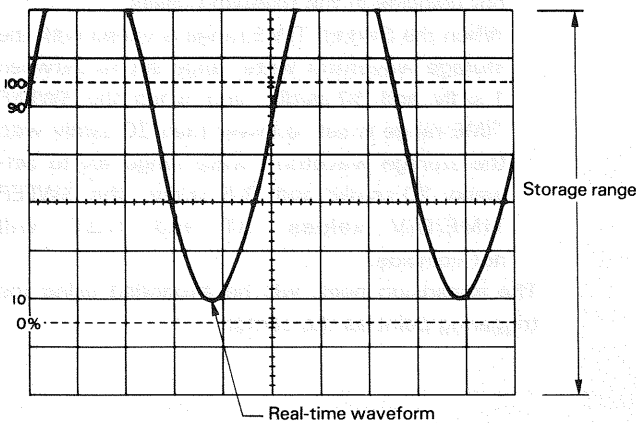

Fig. 18

When part of the waveform is out of the storage range after the AC-GND-DC switch is set to AC, with the DISPLAY MODE set to REAL

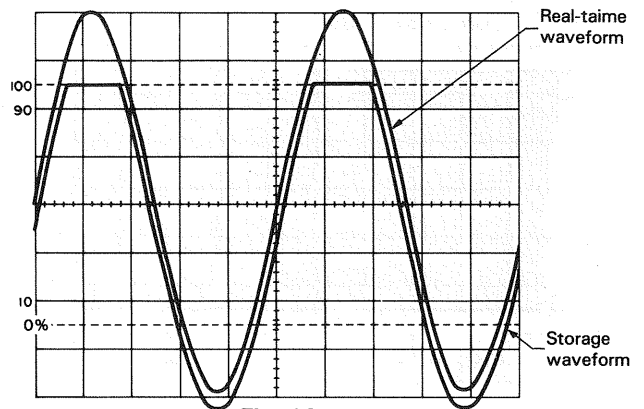

Fig. 19

Example: When the storage waveform is clamped by adjusting the POSITION and the STORAGE POSI to set the waveform to the center of the CRT. With the DISPLAY MODE set to R & S, and after storing the waveform in DISPLAY MODE-STORE, in this condition

NOTE: When storing, if the SWEEP TIME range (sampling clock) is set at an improper level (when the sampling point is lower by 2 points to one period) against the input frequency, an aliasing error will occur. Here is an example in the following: Assuming that the input frequency is constant at 10 kHz, when the SWEEP TIME is set to 20 ms/div (1 sampling error will occur with the stored waveform).

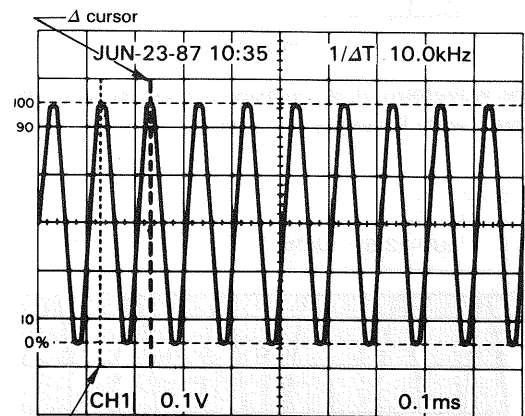
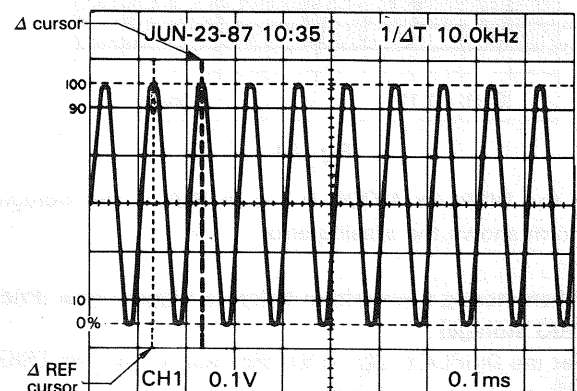

Fig. 20

Real-time waveform with a 10 kHz input frequency



Storage waveform in the proper range (waveform with 200 samples per period)

Fig. 21

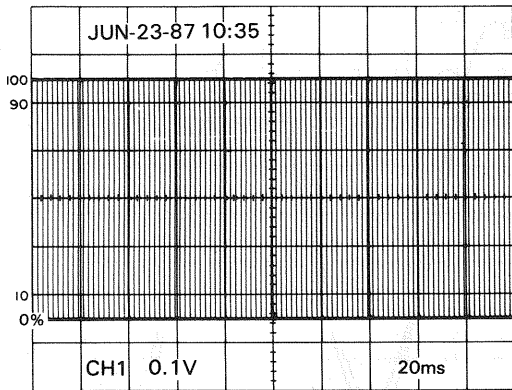

Fig. 22

Real-time waveform when the SWEEP TIME is set to 1/200 with a 10 kHz input frequency

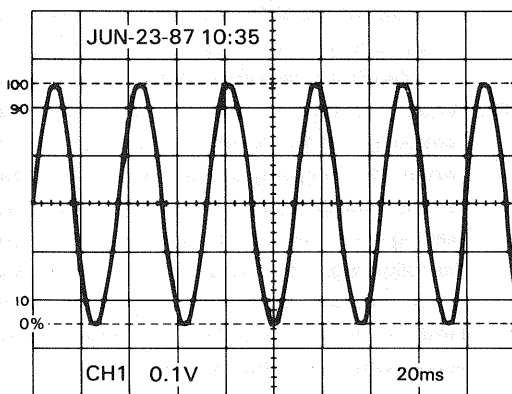

Fig. 23

Storage waveform in an improper range (when aliasing error occurs with 1 sample per period)

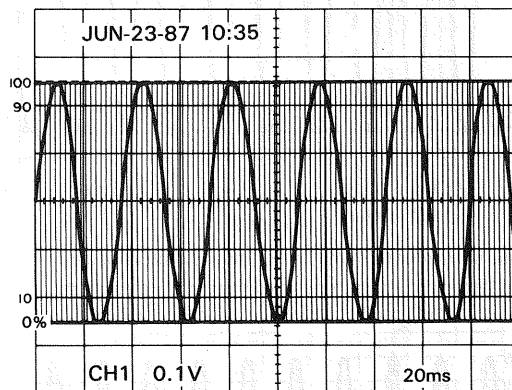

Fig. 24

When the DISPLAY MODE is set to R & S, the storage waveform shows the aliasing error

2. When storing a waveform before a trigger signal (PRE TRIG storage)

- 1) Set the DISPLAY (32) to STORE, and set the PRE TRIG (30) to 2.5, 5, or 7.5 div.

- 2) Set the TRIGGERING MODE (28) to SINGLE-RESET to set the oscilloscope to trigger signal waiting status. (After the WRITE (33) LED lights, the READY (29) LED lights. When the READY LED is lit, it shows that the oscilloscope is in trigger signal waiting mode.)
- 3) When a trigger signal is generated, the waveform will be written into memory for the specified period, and the storage waveform will be displayed on the CRT after writing is completed. At this time, the 5 div. position shows the trigger point, and the position 5 div. to the left of it shows the status before the trigger signal was generated if the PRE TRIG (30) was set to 5 div. **NOTE:** This mode should be started manually to observe the waveform before triggering.

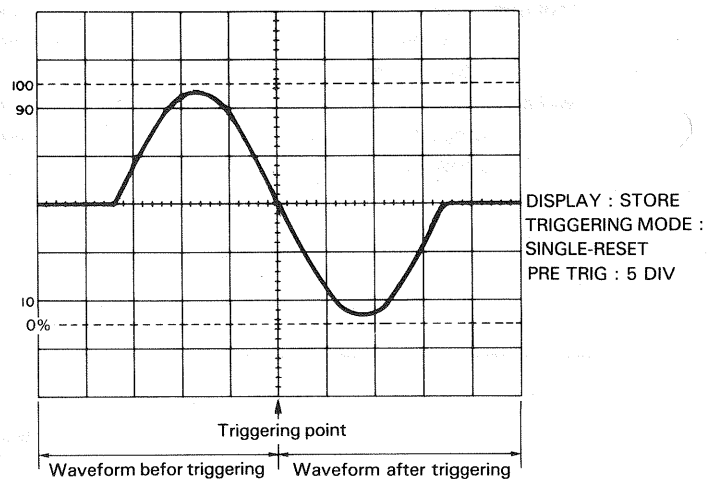

Fig. 25

Example: When storing a burst wave with the PRE TRIG set to 5 div.

3. When using the Expanded Range (SWEEP TIME 10 μs/div ~ 0.5 μs/div.)

NOTE: After storing the waveform, when the SWEEP TIME range is varied, the READOUT display will not coincide in the following cases.

When the SWEEP TIME range is varied with the storage waveform write range set to between 1 s/div and 50 μs/div, and when the SWEEP TIME range is set to lower than 20 μs/div with the storage waveform write range set to between 20 μs/div and 0.5 μs/div, the SWEEP TIME/DIV values, ΔT and 1/ΔT, will not coincide.

The expansion point will be expanded using the triggering point as the center.

a) When storing a waveform with the SWEEP TIME set to between 20 $\mu\text{s}/\text{div}$ and 0.5 $\mu\text{s}/\text{div}$

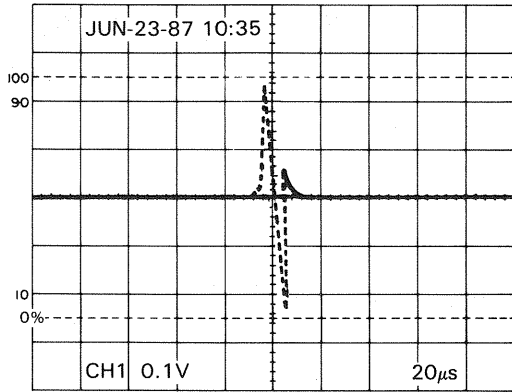

Fig. 26

1) **Example:**When storing a waveform with 20 $\mu\text{s}/\text{div}$, by pre-triggering.
 DISPLAY MODE : STORE
 TRIGGERING MODE : SINGLE-RESET
 PRE TRIG : 5 DIV

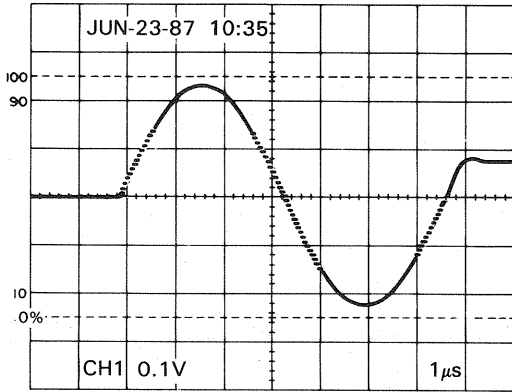

Fig. 27

2) **Example:**When the waveform in the upper figure is expanded, by magnifying the Sweep Time by 20.
 (Horizontal resolution: 10 dot/div.)

The horizontal resolution is derived from the following equation:

$$\text{Resolution} = \frac{\text{Resolution in normal sweep mode (200 dot/div)}}{\frac{\text{Reference sweep range in expansion mode (20 } \mu\text{s/div)}}{\text{Sweep range in expansion mode}}}$$

b) When storing a waveform with the SWEEP TIME set to between 1 s/div and 50 $\mu\text{s}/\text{div}$

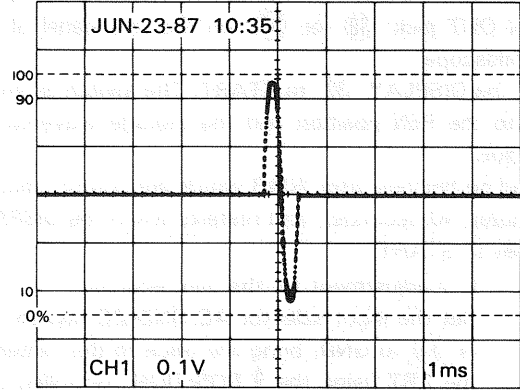

Fig. 28

1) **Example:**When storing a waveform with 1 s/div, by pre-triggering.
 DISPLAY MODE : STORE
 TRIGGERING MODE : SINGLE-RESET
 PRE TRIG : 5 DIV

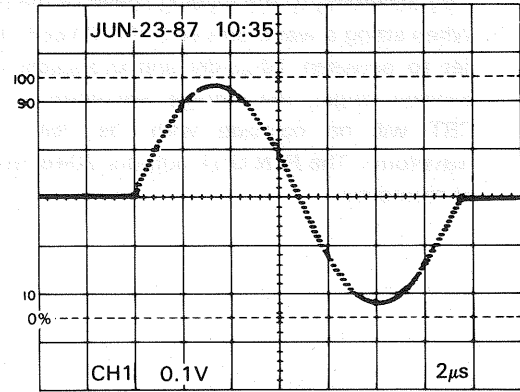

Fig. 29

2) **Example:**When the waveform in the upper figure is displayed using the expansion range (Horizontal resolution: 20 dots/div.)
 In this, the Sweep Time indicator, 2 $\mu\text{s}/\text{div}$., in expansion mode cannot be used as it is. the sweep range can be obtained by the following equation:

$$\text{Real sweep range} = \left(\frac{\text{Sweep range in storage mode}}{\frac{\text{Reference sweep range in expansion mode (20 } \mu\text{s/div)}}{\text{Displayed sweep range}}} \right)$$

Therefore, the sweep range in this expansion mode can be derives by the following equation:

$$\begin{aligned} \text{Sweep range} &= \frac{1 \text{ ms}}{20 \mu\text{s}} \times 2 \mu\text{s} \\ &= 100 \mu\text{s/div.} \end{aligned}$$

4. Readout to Pen Recorder

- 1) Set the DISPLAY (32) to STORE, and store the input signal to be recorded onto the pen recorder.
- 2) Connect the input terminal of the pen recorder to the PEN OUT jack (38) or (39) on the rear panel of the oscilloscope.
- 3) Set the DISPLAY (32) to START. The switch is returned to the PEN position and the storage waveform is output.

Read out finishes after 2048 words are output (about 1 minutes 40 seconds), and restarts when the DISPLAY is set to START.

NOTE: 1. 0 V adjustment for the pen recorder

Set the input selector AC-GND-DC switch (5) or (11) to GND, bring the trace to the center of the CRT using the \blacklozenge POSITION controller, and set the DISPLAY switch (32) to STORE to write GND in the memory. Then, set the DISPLAY (32) to PEN START to output 0 V from the PEN OUT jack. Adjust the DC OFFSET of the pen recorder so that the voltage is 0 V on the pen recorder.

2. While the storage waveform is being output to the pen recorder, the READOUT disappears from the CRT. The waveform on the CRT will vary according to the reading speed of the pen.
3. When string a waveform with the SWEEP TIME set to between $10 \mu\text{s}/\text{div}$ and $0.5 \mu\text{s}/\text{div}$ (expansion range), the storage waveform on the CRT will no coincide with the PEN OUT waveform. The PEN OUT outputs 2048 words of memories.

APPLICATIONS

PROBE COMPENSATION

For accurate measurement, perform appropriate probe correction prior to measurement.

1. Connect a probe to the INPUT terminal, and set each switch so that normal sweep is displayed.
2. Connect the probe to the CAL terminal on the front panel, and adjust the SWEEP TIME/DIV switch so that several cycles of this signal are displayed.
3. Adjust compensation trimmer on probe for optimum square wave waveshape (minimum overshoot, rounding off, and tilt).

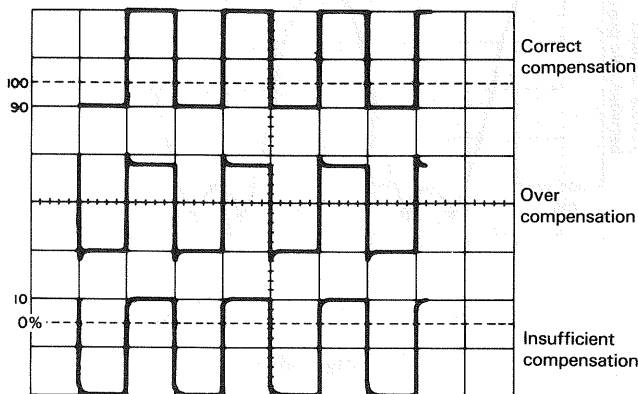

Fig. 30

TRACE ROTATION COMPENSATION

Rotation from a horizontal trace position can be the cause of measurement errors.

Adjust the controls for a single display. Set the AC-GND-DC switch to GND and A TRIG MODE to AUTO. Adjust the POSITION control such that the trace is over the center horizontal graticule line. If the trace appears to be rotated from horizontal, align it with the center graticule line using the TRACE ROTATION control located on the front panel.

1. DC VOLTAGE MEASUREMENT

Two types of measurement methods are provided; ordinary measurement and cursor measurement.

(1) Ordinary Measurement

To measure waveform DC level, carry out the following operations:

1. Connect the signal to be measured to the INPUT jack. For the channel which is selected by the vertical MODE switch, set the AC-GND-DC switch to DC and adjust the controls for normal sweep. Then adjust the VOLTS/DIV and SWEEP TIME/DIV controls to the optimum settings for measurement of the waveform. The VARIABLE switch should be set to CAL.
2. Set the TRIG MODE switch to AUTO and AC-GND-DC switch to GND. The trace displayed at this time is the GND level (reference line). Using the POSITION control, adjust the trace position to the desired reference level position, making sure not to disturb this setting once made.

3. Set the AC-GND-DC switch to the DC position to observe the input waveform, including its DC component. If an appropriate reference level or VOLTS/DIV setting was not made, the waveform may not be visible on the CRT screen at this point. If so, reset VOLTS/DIV and/or the POSITION control.
4. Use the POSITION control to bring the portion of the waveform to be measured to the center vertical graduation line of the CRT screen.
5. Measure the vertical distance from the reference level to the point to be measured, (the reference level can be rechecked by setting the AC-GND-DC switch again to GND).

To obtain the real voltage, multiply the vertical distance value by the VOLTS/DIV indication value. When a 10:1 probe is used, further multiply the value by 10. Voltages above and below the reference level are positive and negative values respectively.

- ① When a 10:1 probe is used:
DC level = Vertical distance (div) × VOLTS/DIV setting × 10
- ② With direct measurement
DC level = Vertical distance in divisions × (VOLTS/DIV setting) × (probe attenuation ratio).

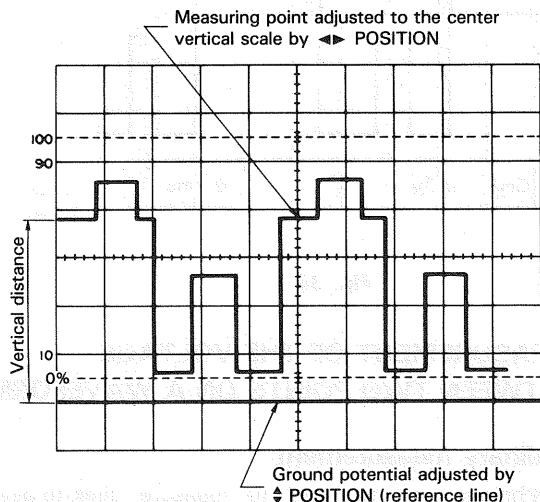

Fig. 31

[EXAMPLE]

For the example, the point being measured is 3.8 divisions from the reference level (ground potential).

If the VOLTS/DIV was set to 0.2 V and a 10:1 probe was used. (See Fig. 31)

Substituting the given values:

$$\text{DC level} = 3.8 \text{ (div)} \times 0.2 \text{ (V)} \times 10 = 7.6 \text{ V}$$

(2) CURSOR measurement

- 1) Make the GND luminescent line be displayed by means of ordinary procedures 1) and 2).
- 2) Set the cursor mode to $\Delta V1$ or $\Delta V2$ in accordance with the channel to be used.
- 3) Adjust the Δ REF cursor (reference line) to the GND luminescent line.
- 4) Set the AC-GND-DC switch to DC.
- 5) Adjust the Δ cursor to a point to be measured.
- 6) Measured value is displayed in the upper right part on the screen posterior to $\Delta V1$ or $\Delta V2$.

If the attached probe PC-33 is used, measured value including the attenuation ratio is displayed. If a probe incompatible with the readout function is used, measured value is multiplied by the attenuation ratio. Lowering of the Δ cursor below the Δ REF cursor indicates negative voltage, displaying "--".

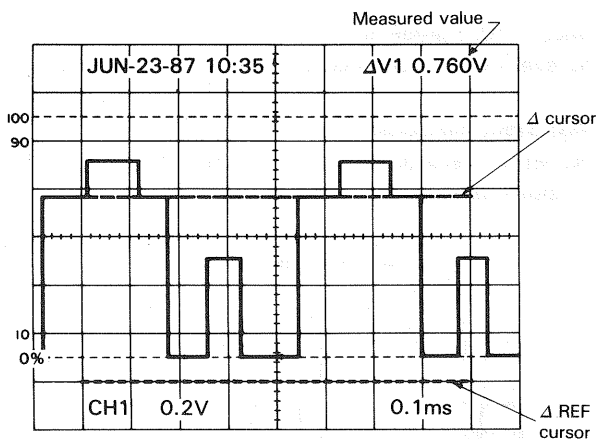

Fig. 32

2. MEASUREMENT OF THE VOLTAGE BETWEEN TWO POINTS ON A WAVEFORM

(1) Ordinary measurement

This technique can be used to measure peak-to-peak voltages.

1. Apply the signal to be measured to the INPUT jack. Set the vertical MODE to the channel to be used. Set the vertical MODE to the channel to be used. Set the AC-GND-DC to AC, adjusting VOLTS/DIV and SWEEP TIME/DIV for a normal display. Set the VARIABLE control to CAL position.
2. Using the \blacktriangleup POSITION control, adjust the waveform position such that one of the two points falls on a CRT graduation line and that the other is visible on the display screen.
3. Using the \blacktriangleleft POSITION control, adjust the second point to coincide with the center vertical graduation line.
4. Measure the vertical distance between the two points and multiply this by the setting of the VOLTS/DIV control.

When a 10:1 probe is used, further multiply the value by 10.

- ① When a 10:1 probe is used.
Volts peak-to-peak
= Vertical distance (div) \times (VOLTS/DIV setting) \times 10
- ② With direct measurement
Voltage between 2 points = Vertical distance (div) \times 2 points.

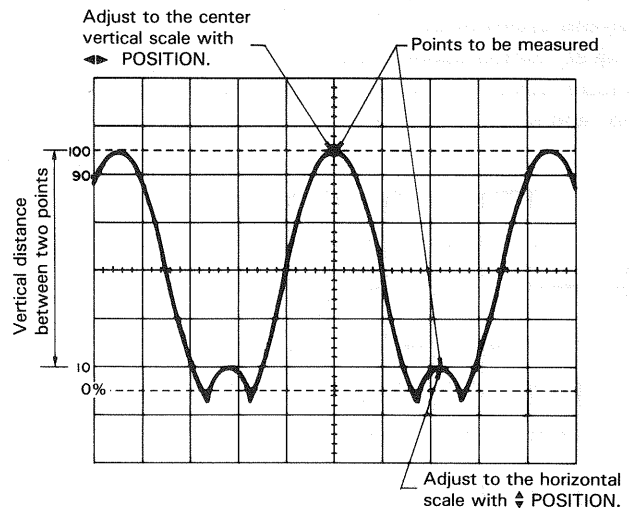

Fig. 33

[EXAMPLE]

For the example, the two points are separated by 4.5 divisions vertically. Set the VOLTS/DIV setting be 0.2 V/div and the probe attenuation be 10:1. (See Fig. 33)

Substituting the given value:

$$\text{Voltage between two points} = 4.5 (\text{div}) \times 0.2 (\text{V/div}) \times 10 = 9.0\text{V}$$

(2) Cursor measurement

- 1) Make waveform to be observed be displayed on the screen in ordinary procedure 1).
- 2) Set the cursor mode to $\Delta V1$ or $\Delta V2$ in accordance with the channel to be used.
- 3) Adjust the Δ REF cursor to a lower point to be measured. and the Δ cursor to another point.
- 4) Measured value is displayed in the upper right part on the screen posterior to $\Delta V1$ or $\Delta V2$.

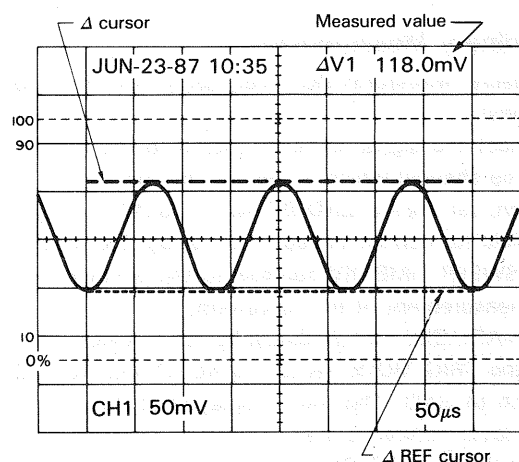

Fig. 34

3. ELIMINATION OF UNDESIRE SIGNAL COMPONENTS

The ADD feature can be conveniently used to cancel out the effect of an undesired signal component which superimposed on the signal you wish to observe.

Procedure:

1. Apply the signal containing an undesired component to the CH1 INPUT jack and the undesired signal itself alone to the CH2 INPUT jack.
2. Set the vertical MODE switch to CHOP and SOURCE switch to CH2. Verify that CH2 represents the unwanted signal in reverse polarity. Reverse the polarity by setting CH2 INV as required.
3. Set the vertical MODE to ADD, SOURCE to V. MODE and CH2 VOLTS/DIV and VARIABLE so that the undesired signal component is cancelled as much as possible. The remaining signal should be the signal you wish to observe alone and free of the unwanted signal.

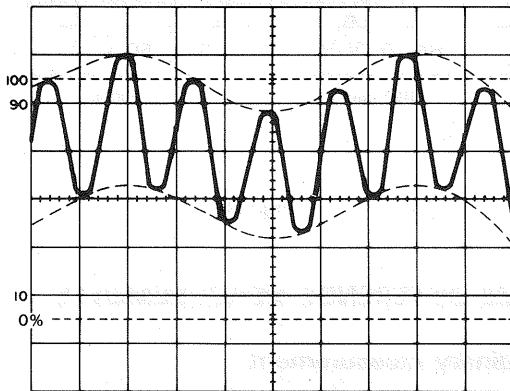

Signal containing undesired component
(Broken lines: undesired component envelope)

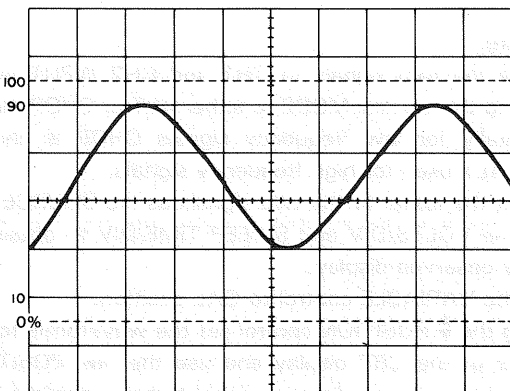

Undesired component signal

Fig. 35

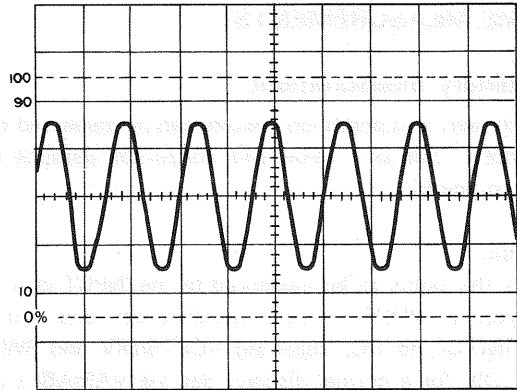

Signal without undesired component

Fig. 36

4. VOLTAGE RATIO MEASUREMENT USING CURSORS

Overshoot of square waves, etc. can be measured in the following procedures:

- 1) Supply signal into the INPUT terminal. Set the V. MODE switch to the channel to be used. the AC-GND-DC selector switch to DC. and each switch so that ordinary sweep is displayed. Then adjust the VOLTS/DIV and SWEEP TIME/DIV for easy waveform observation.
- 2) Turn on the VERTICAL VARIABLE switch to adjust the amplitude to 5 div points (0% and 100%) on the screen as necessity requires with the \blacktriangle POSITION switches.
NOTE: When the SWEEP TIME VARIABLE switch is set to UNCAL, the unit is set to RATIO measurement mode.
- 3) Set the cursor mode to $\Delta V1$ or $\Delta V2$ in accordance with the channel to be used.
- 4) Adjust the Δ REF cursor to 100%.
- 5) Adjust the Δ cursor to a point overshoot at which is to be measured.
- 6) Overshoot voltage ratio with respect to the 5 div (100%) point is displayed in the upper right part on the screen posterior to RATIO.

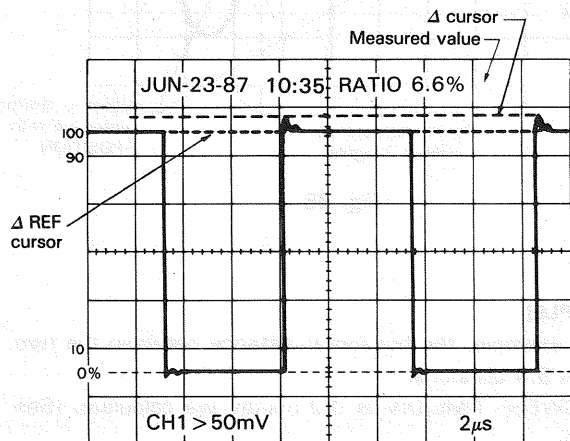

Fig. 37

5. TIME MEASUREMENTS

(1) Ordinary measurement

Time between two points on a wave can be measured from the SWEEP TIME/DIV value and horizontal distance between two points.

Procedure:

1. Apply the signal to be measured to the INPUT jack. Set the vertical MODE to the channel to be used. Set the AC-GND-DC to DC, adjusting VOLTS/DIV and SWEEP TIME/DIV for a normal display. Set the VARIABLE control to CAL position.
2. $\blacktriangleleft \blacktriangleright$ POSITION control to set this point at the intersection of any vertical graduation line. Using the \blacktriangledown POSITION control, set one of the points to be used as a reference to coincide with the horizontal centerline.
3. Measure the horizontal distance between the two points.
Multiply this by the setting of the SWEEP TIME/DIV control to obtain the time between the two points. If horizontal " $\times 10 \text{ MAG}$ " is used, multiply this further by 1/10.

Using the formula:

Time = Horizontal distance (div) \times (SWEEP TIME/DIV setting) \times " $\times 10 \text{ MAG}$ " value⁻¹ (1/10)

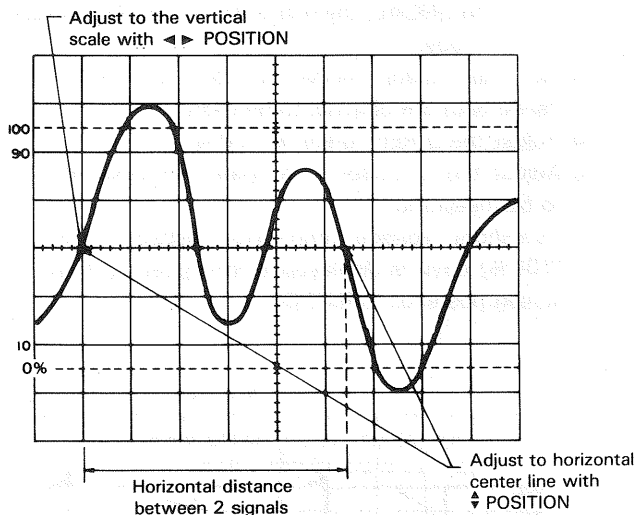

Fig. 38

[EXAMPLE]

For the example, the horizontal distance between the two points is 5.4 divisions. If the SWEEP TIME/DIV is 0.2 ms/div we calculate. (See Fig. 38)

Substituting the given value:

$$\text{Time} = 5.4 \text{ (div)} \times 0.2 \text{ (ms/div)} = 1.08 \text{ ms}$$

(2) Cursor measurement

1. In the same way as the ordinary measurement, adjust the waveform to be measured to an easy-to-observe point.
2. Set the cursor mode to ΔT .
3. Adjust the Δ REF cursor to the left of the two point to be measured, and the Δ cursor to the right.
4. Measured value is displayed in the upper right part on the screen posterior to ΔT .

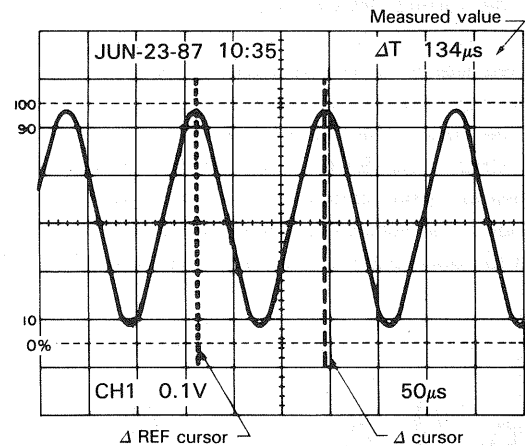

Fig. 39

6. TIME DIFFERENCE MEASUREMENTS

(1) Ordinary measurement

Time difference between two synchronized signals can be measured as follows:

Procedure:

1. Apply the two signals to CH1 and CH2 INPUT jacks. Setting the vertical MODE to either ALT or CHOP mode. Generally for low frequency signals CHOP is chosen with ALT used for high frequency signals.
2. Select the faster of the two signals as the SOURCE and use the VOLTS/DIV and SWEEP TIME/DIV to obtain an easily observed display. Set the VARIABLE control to CAL position.
3. Using the \blacktriangledown POSITION control set the waveforms to the center of the CRT display and use the $\blacktriangleleft \blacktriangleright$ POSITION control to set the reference signal to be coincident with a vertical graduation line.
4. Measure the horizontal distance between the two signals and multiply this distance in divisions by the SWEEP TIME/DIV setting. If " $\times 10 \text{ MAG}$ " is being used multiply this again by 1/10.

Using the formula:

Time = Horizontal distance (div) \times (SWEEP TIME/DIV setting) \times " $\times 10 \text{ MAG}$ " value⁻¹ (1/10)

[EXAMPLE]

For the example, when the horizontal distance between two signals is 4.4 divisions. The SWEEP TIME/DIV is 0.2 (ms/div). (See Fig. 40)

Substituting the given value:

$$\text{Time} = 4.4 \text{ (div)} \times 0.2 \text{ (ms/div)} = 0.88 \text{ ms}$$

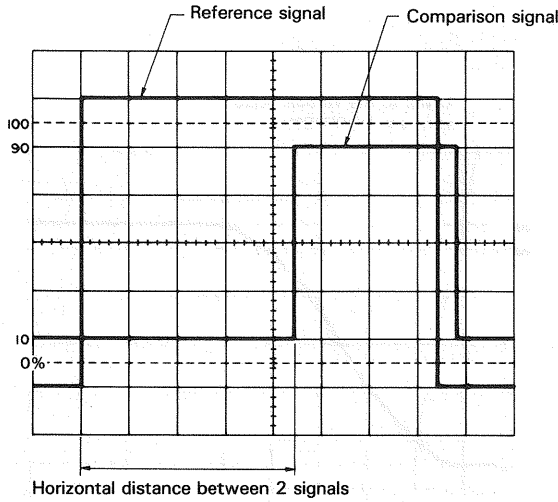

Fig. 40

(2) Cursor measurement

1. In the same way as the ordinary measurement, adjust waveforms to be measured to an easy-to-observe position.
2. Set the cursor mode to ΔT .
3. Adjust the Δ REF cursor to the left point time difference between which is to be measured, and the Δ cursor to the right.
4. Measured value is displayed in the upper right part on the screen posterior to ΔT .

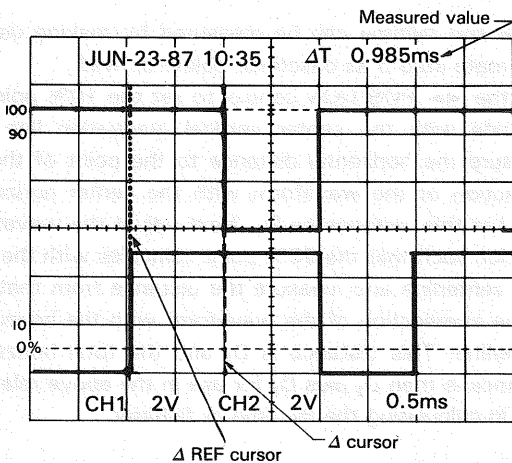

Fig. 41

7. PULSE WIDTH MEASUREMENTS

(1) Ordinary measurement

Pulse width can be measured as follows:

Procedure:

1. Apply the pulse signal to the INPUT jack. Set the vertical MODE switch to the channel to be used.
2. Use the VOLTS/DIV, VARIABLE and \updownarrow POSITION to adjust the waveform such that the pulse is easily observed and such that the center pulse width coincides with the center horizontal line on the CRT screen.
3. Set the SWEEP VARIABLE switch to CAL. Measure the horizontal distance between the intersections of the pulse waveform and CRT center horizontal line in divisions, and multiply the measured distance by the value indicated by SWEEP TIME/DIV. If the "x10MAG" mode is being used, also multiply the product by 1/10.

Using the formula:

$$\text{Pulse width} = \text{Horizontal distance (div)} \times (\text{SWEEP TIME/DIV setting}) \times \text{"x MAG 10" value}^{-1} (1/10)$$

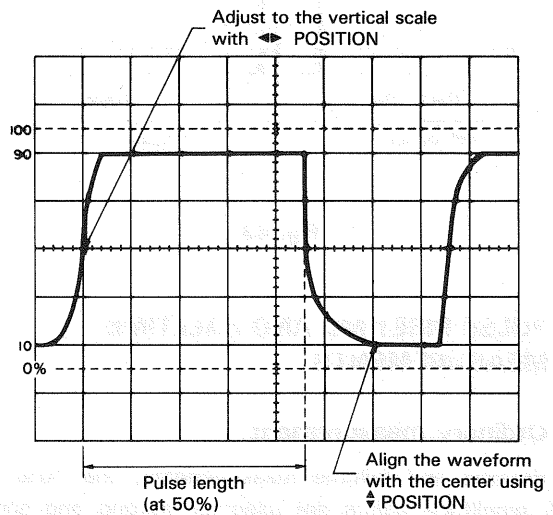

Fig. 42

[EXAMPLE]

For the example, the distance (width) at the center horizontal line is 4.6 divisions and the SWEEP TIME/DIV is 0.2 (ms/div.). (See Fig. 42)

Substituting the given value:

$$\text{Pulse width} = 4.6 \text{ (div)} \times 0.2 \text{ (ms/div)} = 0.92 \text{ ms}$$

(2) Cursor measurement

1. In the same way as the ordinary measurement, adjust waveforms to be measured to an easy-to-observe position.
2. Set the cursor mode to ΔT .
3. Adjust the Δ REF cursor to the left edge of the pulse signal to be measured, and the Δ cursor to the right edge.
4. Measured value is displayed in the upper right part on the screen posterior to ΔT .

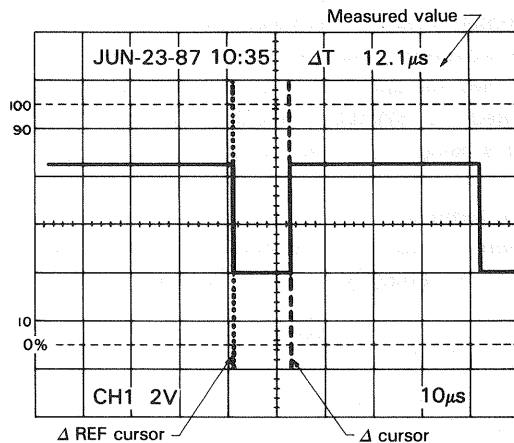

Fig. 43

8. PULSE RISETIME AND FALLTIME MEASUREMENTS

(1) Ordinary measurement

For risetime and falltime measurements, the 10% and 90% amplitude points are used as starting and ending reference points.

Procedure:

1. Apply a signal to the INPUT jack. Set the vertical MODE to the channel to be used.
Use the VOLTS/DIV and VARIABLE to adjust the waveform peak-to-peak height to five divisions.
2. Using the \blacktriangleleft POSITION control and the other controls, adjust the display such that the waveform is centered vertically in the display. Set the SWEEP TIME/DIV to as fast a setting as possible consistent with observation of both the 10% and 90% points. Set the SWEEP VARIABLE control to CAL position.
3. Use the \blacktriangleright POSITION control to adjust the 10% point to coincide with a vertical graduation line and measure the distance in divisions between the 10% and 90% points on the waveform. Multiply this by the SWEEP TIME/DIV and also by 1/10, if "x 10 MAG" mode was used.

NOTE: The graticule on the CRT includes the 0, 10, 90, and 100% lines assuming that 5 divisions correspond to 100%. Use them as a reference for accurate measurements.

Using the formula:

$$\text{Risetime} = \text{Horizontal distance (div)} \times (\text{SWEEP TIME/DIV setting}) \times \text{"x 10 MAG" value}^{-1} (1/10)$$

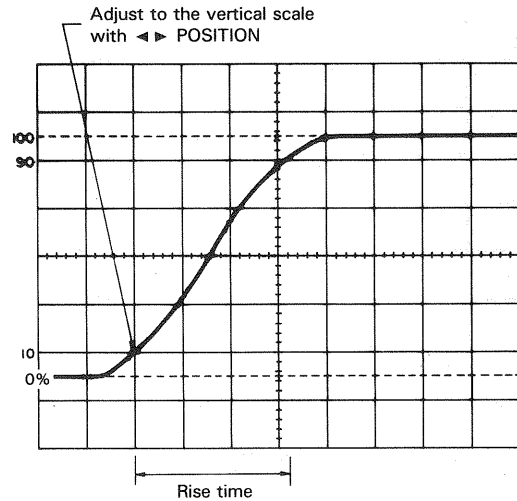

Fig. 44

[EXAMPLE]

For the example, the horizontal distance is 3.3 divisions. The SWEEP TIME/DIV is 2 ($\mu\text{s}/\text{div}$). (See Fig. 44)

Substituting the given value:

$$\text{Risetime} = 3.3 (\text{div}) \times 2 (\mu\text{s}/\text{div}) = 6.6 \mu\text{s}$$

Risetime and falltime can be measured by making use of the alternate step 3 as described below as well.

4. Use the \blacktriangleleft POSITION control to set the 10% point to coincide with the center vertical graduation line and measure the horizontal distance to the point of the intersection of the waveform with the center horizontal line. Let this distance be D_1 . Next adjust the waveform position such that the 90% point coincides with the vertical centerline and measure the distance from that line to the intersection of the waveform with the horizontal centerline. This distance is D_2 and the total horizontal distance is then D_1 plus D_2 for use in the above relationship in calculating the risetime or falltime.

Using the formula:

$$\text{Risetime} = (D_1 + D_2) (\text{div}) \times (\text{SWEEP TIME/DIV setting}) \times \text{"x 10 MAG" value}^{-1} (1/10)$$

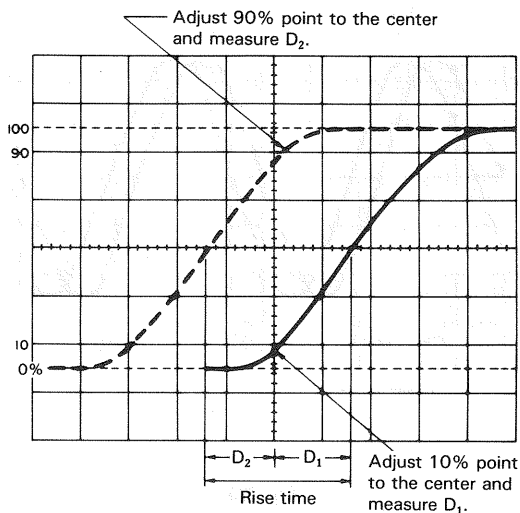

Fig. 45

[EXAMPLE]

For the example, the measured D_1 is 1.6 divisions while D_2 is 1.4 divisions. If SWEEP TIME/DIV is $2 \mu\text{s}/\text{div}$ we use the following relationship. (See Fig. 45)

Substituting the given value:

$$\text{Risetime} = (1.6 + 1.4) (\text{div}) \times 2 (\mu\text{s}/\text{div}) = 6 \mu\text{s}$$

(2) Cursor measurement

1. In the same way as the ordinary measurement, adjust the waveform height displayed on the screen to 5 divisions, and align the bottom and top of the waveform with 0% and 100% respectively using the POSITION switches.
2. Set the cursor mode to ΔT .
3. Adjust the Δ REF cursor to the crossing of the waveform and the 10% division of the scale, and the Δ cursor to the crossing of the waveform and the 90% division.
4. Measured value is displayed in the upper right part on the screen posterior to ΔT .

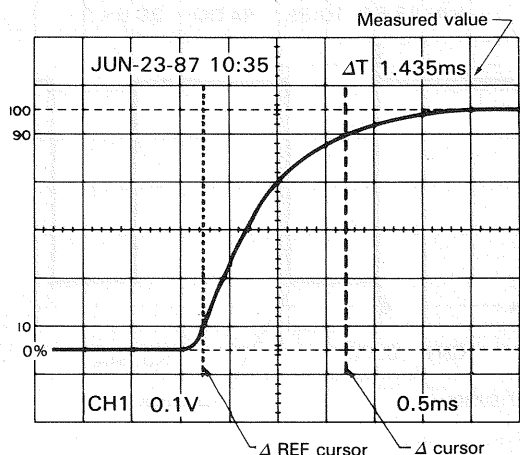

Fig. 46

9. PHASE DIFFERENCE MEASUREMENTS

(1) Ordinary measurement

Phase difference between two sine waves of the same frequency, etc. can be measured as follows:

Procedure:

1. Apply the two signals to the CH1 and CH2 INPUT jacks, setting the vertical MODE to either CHOP or ALT mode.
2. Set the controls to obtain normal sweep. Set the SOURCE switch to select the signal which is leading in phase (reference signal), and adjust the VOLTS/DIV and vertical VARIABLE controls such that the two signals are equal in amplitude.
3. Use the SWEEP TIME/DIV and SWEEP VARIABLE to adjust the display such that one cycle of the signals occupies 8 divisions of horizontal display. Operate POSITION to shift the two signals on the center of the scale. Having set up the display as above, one division now represents 45° in phase.
4. Measure the horizontal distance between corresponding points on the two waveforms.

Using the formula:

$$\text{Phase difference} = \text{Horizontal distance (div)} \times 45^\circ/\text{div}$$

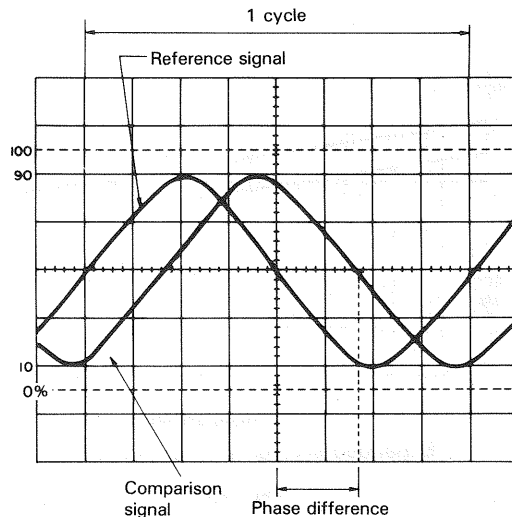

Fig. 47

[EXAMPLE]

For the example, the horizontal distance is 1.7 divisions. (See Fig. 47)

Substituting the given value:

$$\text{The phase difference} = 1.7 (\text{div}) \times 45^\circ/\text{div} = 76.5^\circ$$

The above setup allows 45° per division but if more accuracy is required the SWEEP TIME/DIV may be changed and magnified without touching the VARIABLE control and if necessary the trigger level can be readjusted.

In this case, the phase difference can be obtained from the SWEEP TIME/DIV setting for 8 divisions/cycle and the new SWEEP TIME/DIV setting changed for higher accuracy, by using the following formula.

Phase difference = Horizontal distance of new sweep range (div) $\times 45^\circ/\text{div}$

$$\times \frac{\text{New SWEEP TIME/DIV setting}}{\text{Original SWEEP TIME/DIV setting}}$$

Another simple method of obtaining more accuracy quickly is to simply use $\times 10 \text{ MAG}$ for a scale of $4.5^\circ/\text{div}$.

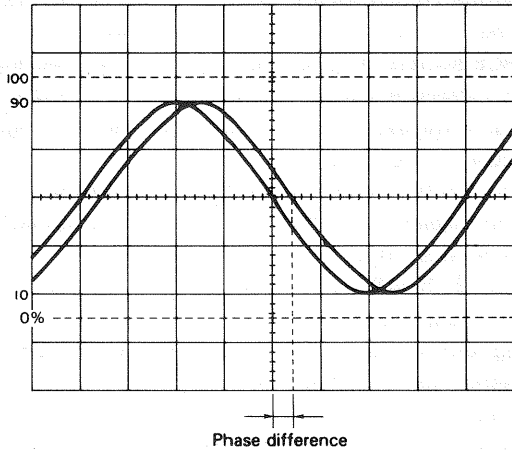

One cycle adjusted to occupy 8 div.

Fig. 48

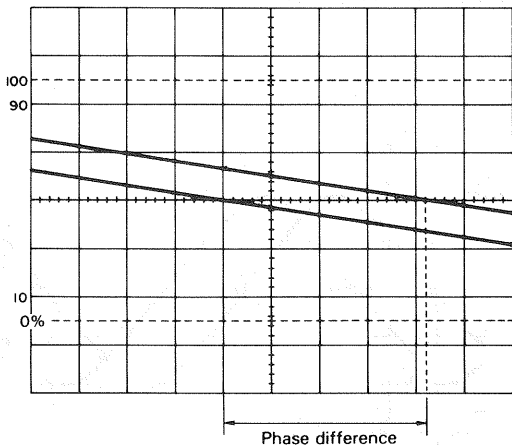

Expanded sweep waveform display.

Fig. 49

(2) Cursor measurement

1. In ordinary procedures 1 and 2, adjust waveforms to be measured to an easy-to-observe position.
2. Adjust 1 cycle's waveform to 5 divisions with the SWEEP TIME/DIV. VARIABLE controller. Then move two waveforms to the center of the scale with the $\blacktriangleleft \blacktriangleright$ POSITION switches.
3. Set the cursor mode to $1/\Delta T$.

NOTE: When the SWEEP TIME VARIABLE switch is set to UNCAL, the unit is set to PHASE measurement mode.

4. Bring the Δ REF cursor to the intersection of the phase-leading signal and center line of the horizontal scale, and bring the Δ cursor to the intersection of the phase-lagging signal and center line of the horizontal scale.
5. Measured value is displayed in the upper right part on the screen posterior to PHASE.

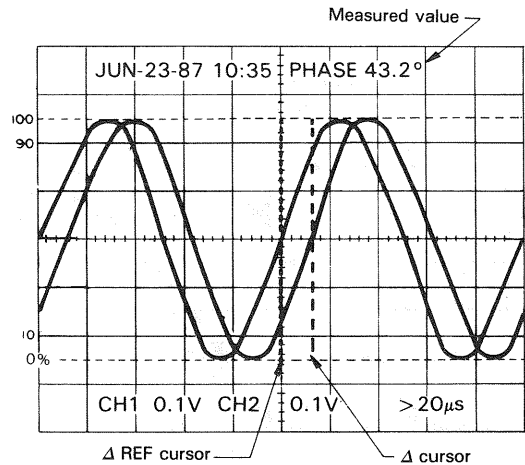

Fig. 50

10. TIME RATIO MEASUREMENT USING CURSORS

Duty ratio of square waves can be measured as follows:

1. Supply signal into the INPUT terminal. Set the V. MODE switch to the channel to be used, the AC-GND-DC selector switch to DC, and each switch so that ordinary sweep is displayed. Then adjust the VOLTS/DIV and SWEEP TIME/DIV for easy waveform observation.
2. Turn the SWEEP TIME VARIABLE switch on to adjust 1 cycle's waveform to 5 divisions on the screen with the $\blacktriangleleft \blacktriangleright$ POSITION switches as necessity requires.

NOTE: When the SWEEP TIME VARIABLE switch is set to UNCAL, the unit is set to RATIO measurement mode.

3. Set the cursor mode to ΔT .
4. Adjust the Δ REF cursor to the left of the two points to be measured, and the Δ cursor to the right.
5. Duty ratio with respect to the 5 div (100%) point is displayed percentagewise in the upper right part on the screen posterior to RATIO.

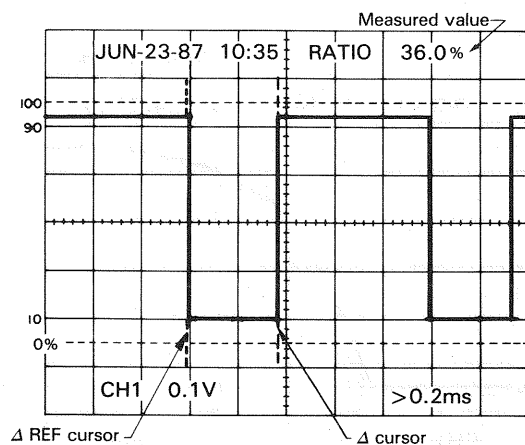

Fig. 51

11. FREQUENCY MEASUREMENTS

Frequency measurements are made by measuring the period of one cycle of waveform and taking the reciprocal of this time value as the frequency.

Procedure:

1. Following the procedure described in section 5 "Time Measurements", measure the time of each cycle. The figure obtained in the signal period.
2. The frequency is the reciprocal of the period measured.

Using the formula:

$$\text{Freq} = \frac{1}{\text{period}}$$

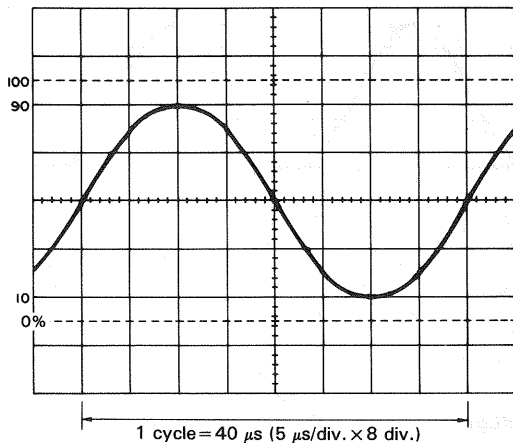

Fig. 52

[EXAMPLE]

A period of 40 μs is observed and measured. (See Fig. 52)

Assuming that SWEEP TIME/DIV indicates 5 $\mu\text{s}/\text{div}$, substituting the given Value:

$$\text{Freq} = 1/[40 \times 10^{-6}] = 2.5 \times 10^4 = 25 \text{ kHz}$$

While the above method relies on the measurement directly of the period of one cycle, the frequency may also be measured by counting the number of cycles present in a given time period.

1. Apply the signal to the INPUT jack. Set the vertical MODE to the channel to be used and adjusting the various controls for a normal display. Set the VARIABLE control to CAL position.
2. Count the number of cycles of waveform between a chosen set of graticules in the vertical axis direction. Using the horizontal distance between the vertical lines used above and the SWEEP TIME/DIV, the time span may be calculated. Multiply the reciprocal of this value by the number of cycles present in the given time span. If "x 10 MAG" is used multiply this further by 10. Note that errors will occur for displays having only a few cycles.

Using the formula:

$$\text{Freq} = \frac{\# \text{ of cycles} \times " \times 10 \text{ MAG} " \text{ value}}{\text{Horizontal distance (div)} \times \text{SWEEP TIME/DIV setting}}$$

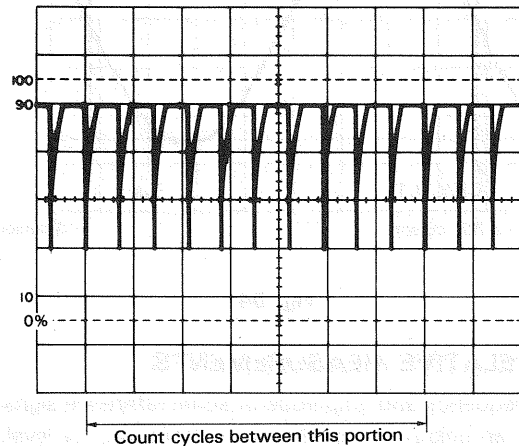

Fig. 53

[EXAMPLE]

For the example, within 7 divisions there are 10 cycles. The SWEEP TIME/DIV is 5 $\mu\text{s}/\text{div}$. (See Fig. 53)

Substituting the given value:

$$\text{Freq} = \frac{10}{7 \text{ (div)} \times 5 \text{ (}\mu\text{s/div)}}$$

$$\approx 285.7 \text{ kHz}$$

Cursor measurement

1. Apply the signal to INPUT jack, setting the vertical MODE switch to the channel to be used and adjusting the various controls for a normal display. VOLTS/DIV and SWEEP TIME/DIV to obtain an easily observed display. Set the VARIABLE to CAL.
2. Set the cursor mode to 1/ ΔT .
3. Adjust the Δ REF cursor to the left of the points to be measured, and the Δ cursor to the right.
4. Measured value is displayed in the upper part on the screen posterior to 1/ ΔT .

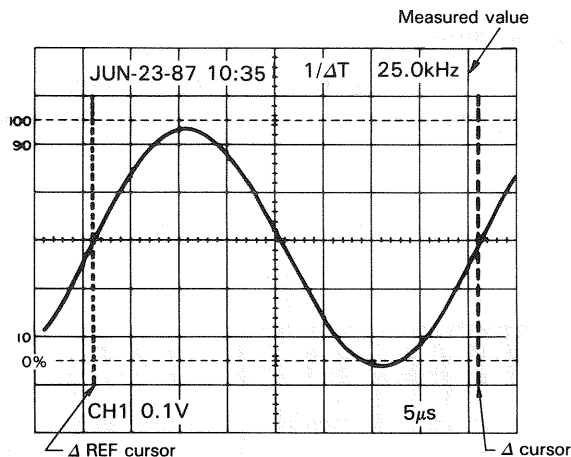

Fig. 54

12. RELATIVE MEASUREMENTS

If the frequency and amplitude of some reference signal are known, an unknown signal may be measured for level and frequency without use of the VOLTS/DIV or SWEEP TIME/DIV for calibration.

The measurement is made in units relative to the reference signal.

★ Vertical Sensitivity

Setting the relative vertical sensitivity using a reference signal.

Procedure:

1. Apply the reference signal to the INPUT jack and adjust the display for a normal waveform display. Adjust the VOLTS/DIV and VARIABLE so that the signal coincides with the CRT face's graduation lines. After adjusting, be sure not to disturb the setting of the VARIABLE control.
2. The vertical calibration coefficient is now the reference signal's amplitude (in volts) divided by the product of the vertical amplitude set in step 1 and the VOLTS/DIV setting.

Using the formula:

Vertical coefficient

$$= \frac{\text{Voltage of the reference signal (V)}}{\text{Vertical amplitude (div)} \times \text{VOLTS/DIV setting}}$$

3. Remove the reference signal and apply the unknown signal to the INPUT jack, using the VOLTS/DIV control to adjust the display for easy observation. Measure the amplitude of the displayed waveform and use the following relationship to calculate the actual amplitude of the unknown waveform.

Using the formula:

$$\begin{aligned} \text{Amplitude of the unknown signal (V)} \\ = \text{Vertical distance (div)} \times \text{Vertical coefficient} \\ \times \text{VOLTS/DIV setting} \end{aligned}$$

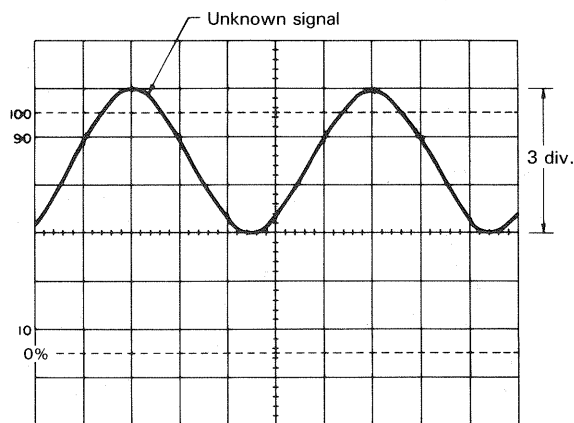
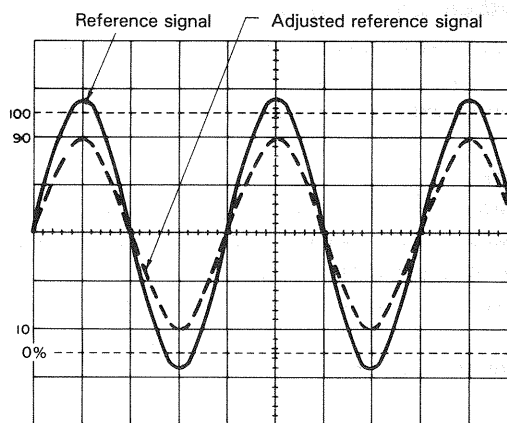

Fig. 55

[EXAMPLE]

For the example, the VOLTS/DIV is 1 V/div.

The reference signal is 2 Vrms. Using the VARIABLE, adjust so that the amplitude of the reference signal is 4 divisions. (See Fig. 55)

Substituting the given value:

$$\begin{aligned} \text{Vertical coefficient} &= \frac{2 \text{ Vrms}}{4 \text{ (div)} \times 1 \text{ (V/div)}} \\ &= 0.5 \end{aligned}$$

Then measure the unknown signal and VOLTS/DIV is 5 V and vertical amplitude is 3 divisions.

Substituting the given value:

$$\begin{aligned} \text{Effective value of unknown signal} &= 3 \text{ (div)} \times 0.5 \times 5 \text{ (V/div)} \\ &= 7.5 \text{ V rms} \end{aligned}$$

★ Period

Setting the relative sweep coefficient with respect to a reference frequency signal.

Procedure:

1. Apply the reference signal to the INPUT jack, using the VOLTS/DIV and VARIABLE to obtain an easily observed waveform display. Using the SWEEP TIME/DIV and VARIABLE adjust one cycle of the reference signal to occupy a fixed number of scale divisions accurately. After this is done be sure not to disturb the setting of the VARIABLE control.

2. The Sweep (horizontal) calibration coefficient is then the period of the reference signal divided by the product of the number of divisions used in step 1 for setup of the reference and the setting of the SWEEP TIME/DIV control.

Using the formula:
Sweep coefficient

$$= \frac{\text{Period of the reference signal (sec)}}{\text{horizontal width (div)} \times \text{SWEEP TIME/DIV setting}}$$

3. Remove the reference signal and input the unknown signal, adjusting the SWEEP TIME/DIV control for easy observation.

Measure the width of one cycle in divisions and use the following relationship to calculate the actual period.

Using the formula:

$$\text{Period of unknown signal} = \text{Width of 1 cycle (div)} \times \text{sweep coefficient} \times \text{SWEEP TIME/DIV setting}$$

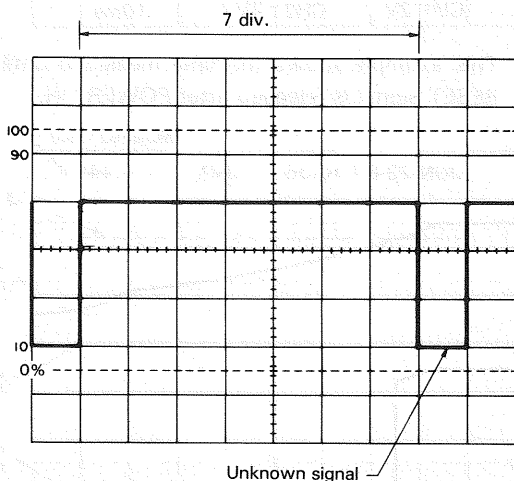
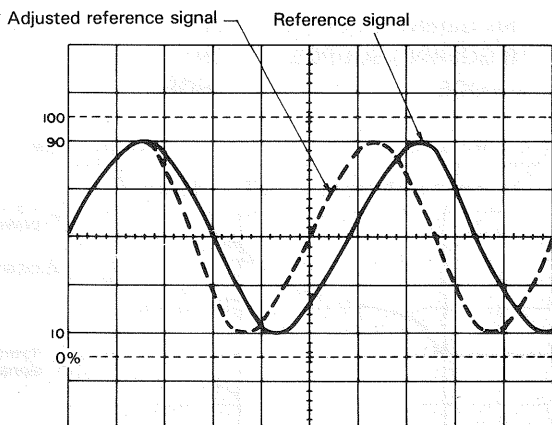

Fig. 56

[EXAMPLE]

SWEEP TIME/DIV is 0.1 ms and apply 1.75 kHz reference signal. Adjust the VARIABLE so that the distance of one cycle is 5 divisions.

Substituting the given value:

$$\text{Horizontal coefficient} = \frac{1.75 \text{ (kHz)}^{-1}}{5 \text{ (div)} \times 0.1 \text{ (ms/div)}} \approx 1.143$$

Then, SWEEP TIME/DIV is 0.2 ms/div and horizontal amplitude is 7 divisions. (See Fig. 56)

Substituting the given value:

$$\text{Pulse width} = 7 \text{ (div)} \times 1.143 \times 0.2 \text{ (ms/div)} \approx 1.6 \text{ ms}$$

13. APPLICATION OF X-Y OPERATION

★ Phase Shift Measurement

A method of phase measurement requires calculations based on the Lissajous patterns obtained using X-Y operations. Distortion due to non-linear amplification also can be displayed.

A sine wave input is applied to the audio circuit being tested. The same sine wave input is applied to the vertical input of the oscilloscope, and the output of the tested circuit is applied to the horizontal input of the oscilloscope. The amount of phase difference between the two signals can be calculated from the resulting waveform.

To make phase measurements, use the following procedure.

1. Using an audio signal generator with a pure sinusoidal signal, apply a sine wave test signal at the desired test frequency to the audio network being tested.
2. Set the signal generator output for the normal operating level of the circuit being tested. If desired, the circuit's output may be observed on the oscilloscope. If the test circuit is overdriven, the sine wave display on the oscilloscope is clipped and the signal level must be reduced.
3. Connect the channel 2 probe to the output of the test circuit.
4. Select X-Y operation by placing the TRIG MODE switch in the X-Y position.
5. Connect the channel 1 probe to the input of the test circuit.
(The input and output test connections to the vertical and horizontal oscilloscope inputs may be reserved.)
6. Adjust the channel 1 and 2 gain controls for a suitable viewing size.
7. Some typical results are shown in Fig. 58.

If the two signals are in phase, the oscilloscope trace is a straight diagonal line. If the vertical and horizontal gain are properly adjusted, this line is at a 45° angle. A 90° phase shift produces a circular oscilloscope pattern. Phase shift of less (or more) than 90° produces an elliptical oscilloscope pattern. The amount of phase shift can be calculated from the oscilloscope trace as shown in Fig. 57.

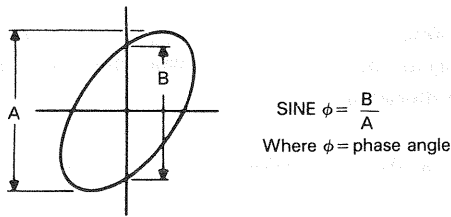

Fig. 57 Phase shift calculation

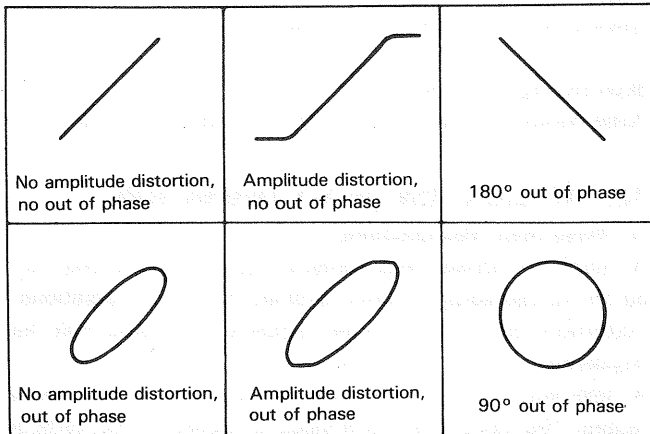

Fig. 58 Typical phase measurement oscilloscope display

★ Frequency Measurement

1. Connect the sine wave of known frequency to the channel 2 INPUT jack of the oscilloscope and select X-Y operation. This provides external horizontal input.
2. Connect the vertical input probe (CH1 INPUT) to the unknown frequency.
3. Adjust the channel 1 and 2 size controls for convenient, easy-to-read size of display.
4. The resulting pattern, called a Lissajous pattern, shows the ratio between the two frequencies.

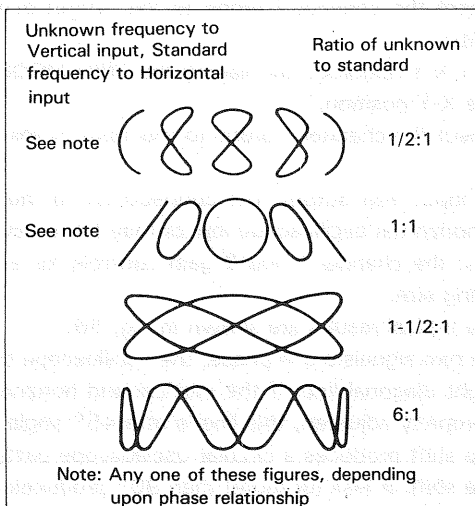

Fig. 59 Lissajous waveforms used for frequency measurement

APPLICATION EXAMPLES AS A DIGITAL STORAGE OSCILLOSCOPE

Waveform observation of a low-frequency signal, or single phenomenon, etc., that is difficult with a normal oscilloscope can be made easily, and the applicable range is greatly widened.

Some application examples are described in the following:

(1) Observation of the POWER RESET signal when switching the power ON and OFF

A POWER RESET signal occurs in all digital equipment whenever the power is switched ON/OFF. This is a difficult waveform to observe with a conventional oscilloscope because it is a transient, single-shot phenomenon. However, when used in storage mode, the waveform observation is quite easily made possible.

1. The relationship between the rising edge of the +5 V power supply and the RESET signal is shown.

DISPLAY MODE : STORE
TRIGGERING MODE : SINGLE - PRE. TRIG.
2.5 DIV
TRIGGERING COUPLING : DC
TRIGGERING SOURCE : CH1
V-MODE : CHOP

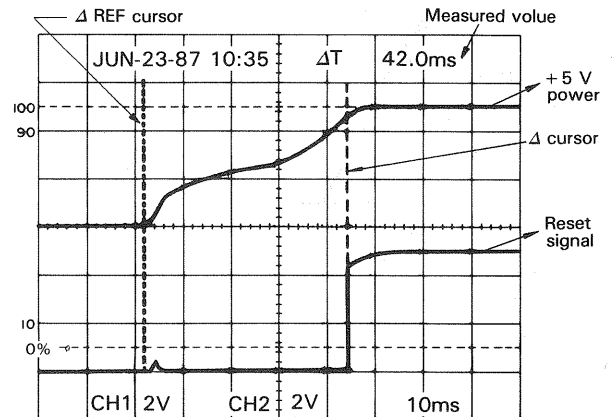

This example shows the time measured until the RESET signal is released after POWER ON.

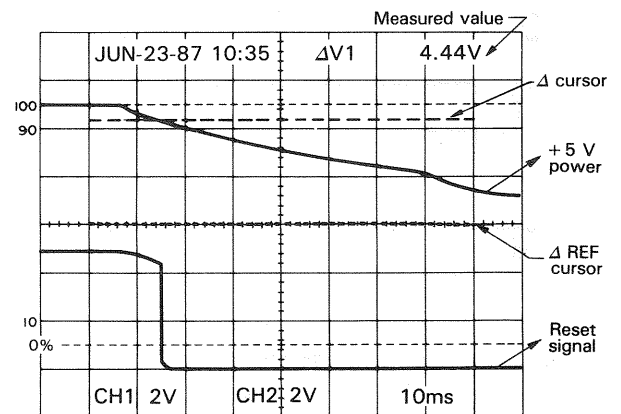

Fig. 60

This example shows the measured voltage of the +5 V power supply when the RESET signal is active during POWER OFF.

(2) Low frequency observation

In conventional oscilloscopes, the low frequency signal can be observed as a spot and waveform observation is difficult. However, with the storage mode of this unit, the low-frequency waveform can easily be observed.

An example of the period measurement and voltage measurement of low frequency signals are shown below:

- DISPLAY MODE : STORE
- TRIGGERING MODE : NORM
- TRIGGERING COUPLING : HF rej
- TRIGGERING SOURCE : CH 1
- V-MODE : CH 1

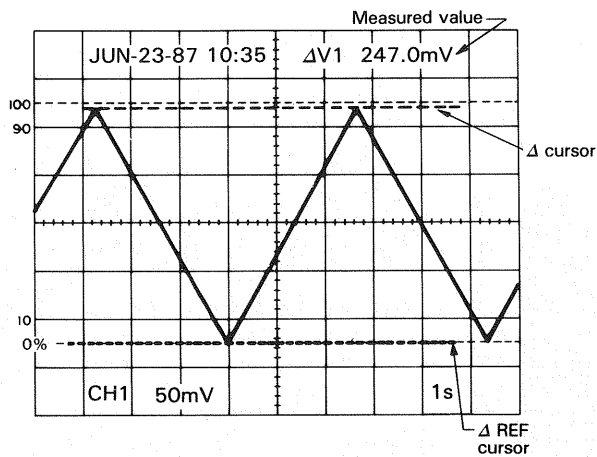
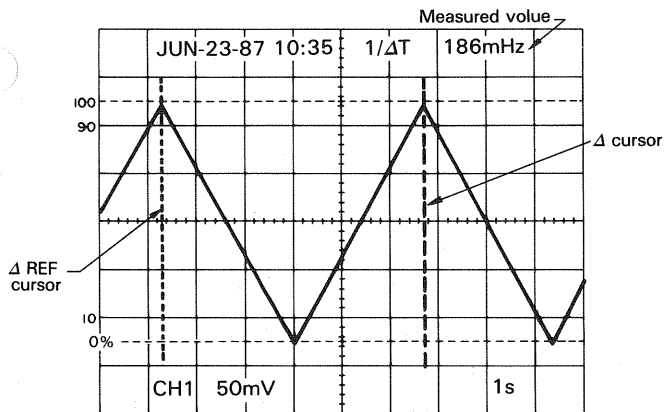

Fig. 61

MAINTENANCE

⚠ Caution : Read this page carefully to keep your safety.

For Electric Shock Protection:

Be sure to disconnect the power cable from the socket before conducting the following operation.

REPLACING THE FUSE

In case the fuse has blown, locate the cause. If the fuse itself is the cause, replace it as follows:

1. Pull the plug of the power cord from the power outlet.
2. Remove the fuse holder in the rear panel using a standard screwdriver (see Fig. 62).
3. Take out the blown fuse, and in its place, insert a new fuse.
4. Set the label of your line voltage to the mark ▼, then plug the fuse holder containing the new fuse into the rear panel.

CHANGING THE SUPPLY VOLTAGE

Remove the fuse holder in the rear panel using a standard screwdriver. Then set the label of your line voltage to the mark ▼ and plug the fuse holder back into place. When changing the supply setting from 100/120 V to 220/240 V, change the 1.2 A fuse for a 0.8 A one. (see Fig. 62)

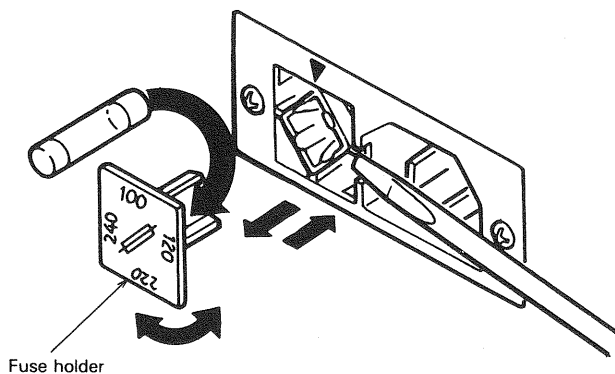

Fig. 62

RESETTING THE READOUT CALENDAR AND CLOCK DISPLAY

The readout calendar and clock display can be changed and reset with the DATE change switch located on the right end of the rear side on the bottom. (This can be performed without removing the case.)

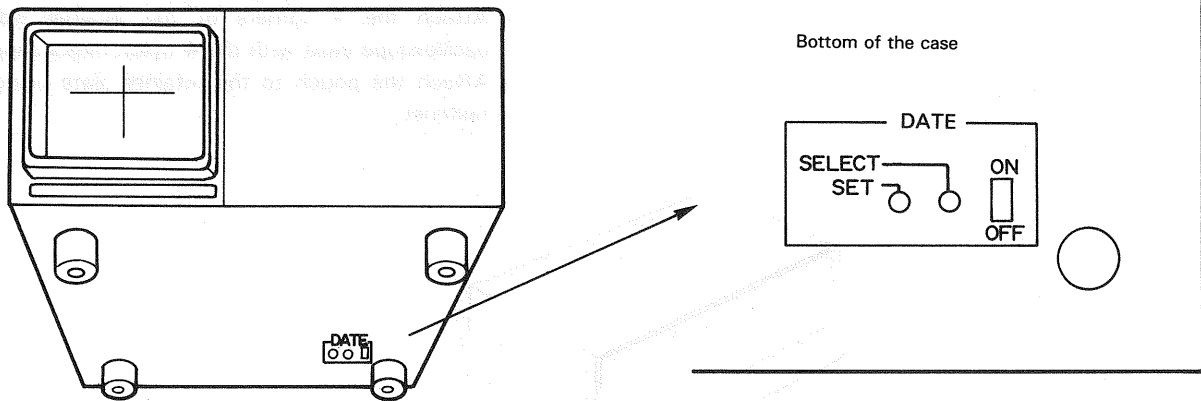

Fig. 63

NOTE: When performing the following operations, be sure to use an insulated stick.

(1) ON/OFF

This switches the calendar and clock display on and off. When switched on, the display will appear on the CRT, and will go out when switched off.

(2) SELECT

This is used to select the section of the calendar and clock display to be corrected. When this button is pressed, correction mode is activated and the "month" indication will blink. Pressing the button again will move the blinking position to the 10's column, for the "date" indication. In this way, each time the button is pressed, the blinking position is shifted to the right one column sequentially. Once the blinking position reaches the "minutes" indication and the button is pressed again, all indications will be lit steadily to show that correction mode has finished.

NOTE: During correction mode (when there is a blinking section within the calendar or clock display), when the control knobs on the front panel are operated, a correct readout display will not be obtained. Be sure to complete correction mode before operating the control knobs.

(3) This is used to correct the calendar and clock display.

When this button is pressed, the blinking position is changed. Set the calendar and clock indications correctly as desired. The "seconds" indication will be set to "0" when correction mode is released.

ACCESSORIES

STANDARD ACCESSORIES INCLUDED

Probe (PC-33)	2 pcs.
Instruction Manual.....	1
Replacement Fuse	
1.2 A	2 pcs.
0.8 A	2 pcs.
Power supply cable	1

OPTIONAL ACCESSORIES

Probe Pouch (MC-78)	1
---------------------------	---

This soft vinyl pouch attaches to the top side oscilloscope housing and provides storage space for two probes and the operators manual. Install the probe pouch as follow;

1. Unsnap the probe pouch from the retainer plate.
2. Align the retainer plate with 4 holes on the top side of the case, with 4 snaps at the top.
3. Attach the 4 corners of the retainer plate to the oscilloscope case with the 4 nylon rivets supplied.
4. Attach the pouch to the retainer plate using the snap fastener.

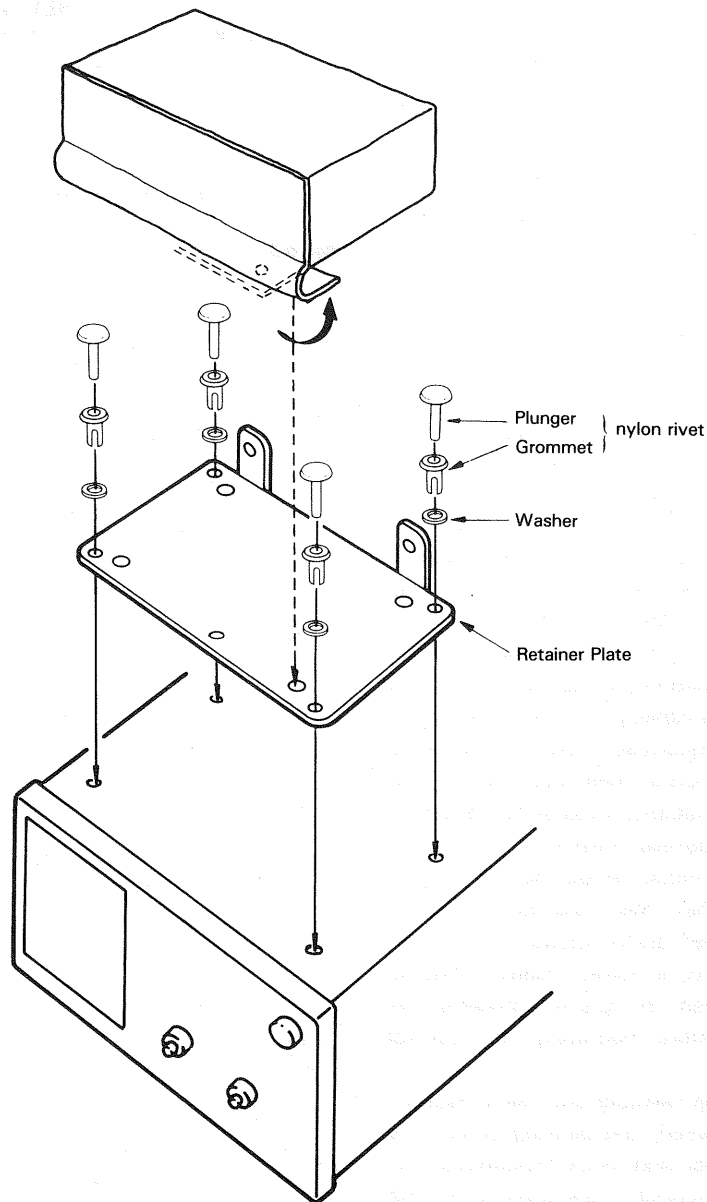

Fig. 64

A product of
KEYWOOD CORPORATION

A product of
KENWOOD CORPORATION
17-5, 2-chome, Shibuya, Shibuya-ku, Tokyo 150, Japan
